

OWNER'S MANUAL

LA5000 LIQUID APPLICATOR



General Information

Thank You and Congratulations on purchasing your new liquid applicator. The purpose of this manual is to assist you in operating and maintaining your liquid applicator.

Please read it carefully, as it furnishes information which will help you achieve years of trouble-free operation. All units can be custom equipped to meet all your spraying needs.



WARNING: To reduce the risk of injury, the user must read and understand the operator's manual before using this product.



WARNING: Cancer and Reproductive Harm
www.P65Warnings.ca.gov

Any Questions, Comments or Problems: Call your nearest AG SPRAY Location and speak with one of our Friendly Technical Support Staff.



[5195082 (09/18)]

BAKERSFIELD, CA 877-724-2236	COLUMBUS, NE 800-274-1025	DOTHAN, AL 800-227-4098	FARGO, ND 701-280-2862	HOPKINSVILLE, KY 800-637-7172	VISIT US ONLINE @ WWW.AGSPRAY.COM
MANKATO, MN 507-388-6295	NEWTON, KS 800-394-7662	PASCO, WA 800-634-2026	TEMPE, AZ 877-974-7166		

Table of Contents

3	Introduction
3	Pre-Operation Checklist
4-7	Operating Instructions
8	Break-In
8	Service & Maintenance
9	Placing in Storage
9	Removing from Storage
10	Greasing
11-26	Parts Breakdowns
28	Hypro Warranty Info
29	Limited Warranty

INTRODUCTION

1. Read and understand the Operators Manual and all safety signs before using.
2. Place all controls in neutral, stop tractor engine, turn monitor off, set park brake, remove ignition key, wait for nozzles to stop spraying before servicing, adjusting, or repairing.
3. Before spraying a field, be familiar with all potential hazards: trees, rocks, ditches, gullies, etc. Plan the spraying route to avoid hazards. Remember you are driving a wide machine. **USE CAUTION WHEN CORNERING.**
4. Keep hands, feet, hair and clothing away from all moving and/or rotating parts.
5. Do not allow riders on the applicator or tractor during operation or transporting.
6. Clear the area of all bystanders, especially children, before starting or filling with water or chemical.
7. Stay away from wing pinch points when folding or extending wings. Keep others away.
8. Stay away from power lines when extending or folding wings. Electrocutation can occur without direct contact.
9. In case of poisoning, get immediate medical attention.
10. Do not eat in the field when side dressing.
11. Before applying pressure to the fertilizer system, make sure all components are tight and that steel lines, hose and couplings are in good condition.
12. Before applying pressure to chemical system make sure that all connections are tight and that all hoses and fittings are in good condition.
13. Review safety instructions annually.

PRE-OPERATION CHECKLIST

Before operating the Applicator and each time thereafter, the following areas should be checked off:

1. Lubricate the machine per the schedule outlined in the "Maintenance Section".
2. Use only a tractor of adequate power and weight to operate the Applicator.
3. Ensure that the machine is properly attached to the tractor. Be sure that a mechanical retainer is installed through the drawbar pin and the safety chain is attached to the drawbar cage. Jack is in full up position.
4. Check the hydraulic system. Ensure that the hydraulic reservoir in the tractor is filled to the required specifications.
5. Inspect all hydraulic lines, hoses, fittings and couplers for tightness. Use a clean cloth to wipe any accumulated dirt from the couplers before connecting to the hydraulic system of the tractor.
6. Check the tires and ensure that they are inflated to the specified pressure.
7. Calibrate the Applicator if it is the start of the season or a new chemical is being used. Calibrate as specified in rate control manual.
8. Check the condition and routing of all chemical hoses and lines. Replace any that are damaged. Re-route those that are rubbing pinched or crimped.
9. Check the spray pattern of each nozzle. Remove and clean or replace any that have an unusual pattern.
10. Remove the steel mesh line filters and wash with clean water. Reinstall.
11. Check that all connections in the electrical system are connected and tight.

OPERATING INSTRUCTIONS

1. Ensure applicator is connected securely to tractor draw bar with clevis pin and safety chain. (Figure 1).

Figure 1

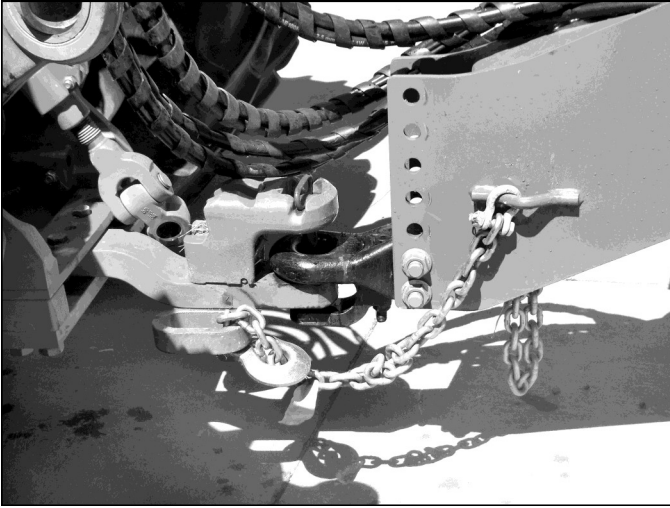

2. Connect applicator hydraulic hoses to the tractor remote couplers. The blue hoses are for the main bar height control. The green hoses are for the outside wing fold. The yellow hoses are for main wing fold on 35' through 55' bars. The red hoses are for the hydraulic pump (Figure 2).

Figure 2

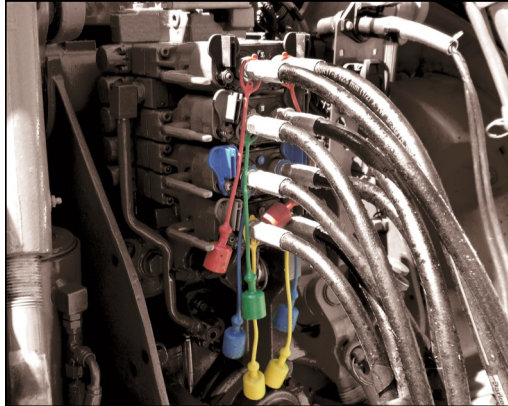

3. Connect wiring harness if using hydraulic pump with rate control.
4. Grease Applicator (Refer to Maintenance).
5. Before road travel, install all locking collars on toolbar cylinders and safety pins on wings.

6. Remove locking collars as needed to maintain a depth of 4 to 5 inches. Constant down pressure on main lift is not recommended (weight of toolbar will keep unit in the ground). Leave hydraulic selector in neutral for field operation.

Figure 3



7. Remove safety pins on wing cylinders. Wing cylinders remote will run in constant while down (Figure 4).

Figure 4



The Applicator is equipped with adjustable down pressure relief valve on wing cylinders. The valve is preset at 800 PSI. This may be adjusted as needed. The relief valve is located on driver's side of linkage arm mount and requires an allen wrench to adjust (clockwise to increase pressure and counterclockwise to decrease pressure (Figure 5).

Figure 5



OPERATING INSTRUCTIONS

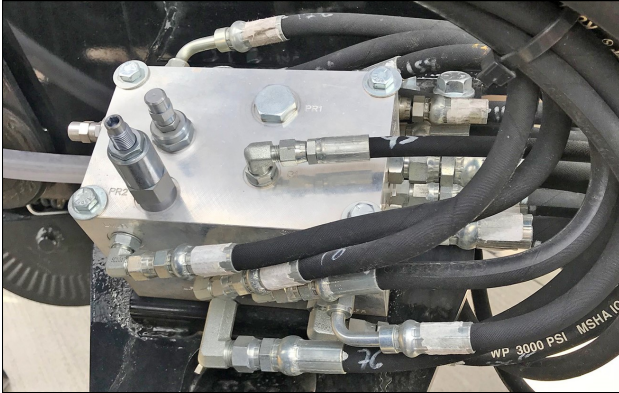

8. After unfolding main wing, engage hydraulic lever in “constant pressure”. This is necessary to allow wings to maintain constant depth and follow uneven terrain, as well as the ability to “gullwing” (Lift both wings evenly when turning).
9. **Field Operation:** When you come to the end of the field.
 1. Lift main section
 2. Pull back on main wing lever long enough to lift both wings slightly (“gullwing”).
 3. After turning, lower main section and wing section and return wing hydraulics to constant pressure.
 4. Main section must be lifted to maximum height to hold gullwing.
10. Check and clean screens as needed.
11. Pump Settings.

Optional Ground Drive Pump

- 11a - Remove transport pin.
- 11b - Use John Blue pump setting slide chart. Loaded radius is 9.75 and sprocket ratio is 32 drive and 18 driven.
- 11c - Set pump to recommended setting.

Optional Hydraulic Drive Pump

- a. Hydraulic pump hoses supplied on the applicator included (1) 1/2” line and (1) 3/4” line. The 1/2” hose is the hydraulic supply (in/pressure) and the 3/4” hose is the return (out/non-pressure).

Note: It is recommended for optimal pump performance that the 3/4” return line connect directly to the tractor hydraulic reservoir (not tractor SCV port). Doing so eliminates possible back pressure restriction on the 3/4” return line. Excessive back pressure restriction can cause hydraulic orbital motor damage/failure.

- b. Proper hydraulic pump disengagement. When shutting off the pump, move the selector to the FLOAT position to allow the centrifugal pump to come to a gradual stop. Standard spool valves, which are found on all tractor hydraulic systems, can cause potentially damaging high peak pressures in the hydraulic system when closed, because of abrupt shutoff of oil flow in both the supply and return lines.

- c. Close and lock down the bypass adjusting screw in the hydraulic motor (if applicable).

Switch rate controller to manual and press the “+” button on TeeJet or “Increase” button on Raven, hold for 8 seconds. Then press the “-” button TeeJet or “Decrease” button on Raven for 4 seconds.

Set the tractor hydraulic flow control valve for minimum hydraulic oil flow to the remote outlet (Tortoise position).

Start the tractor and allow the hydraulic oil to circulate for approximately 10 to 15 minutes or until adequately warmed.

Prime the centrifugal pump with all valves open.

Open the sprayer PWM (pulse width modulation) valve on rate controller and the boom shut-off valves.

Slowly adjust the tractor hydraulic flow control valve until the desired boom pressure is attained.

NOTE: See manufacturer pump operators manual for further setup and maintenance.

NOTE: See specific rate controller manual for further setup and maintenance.

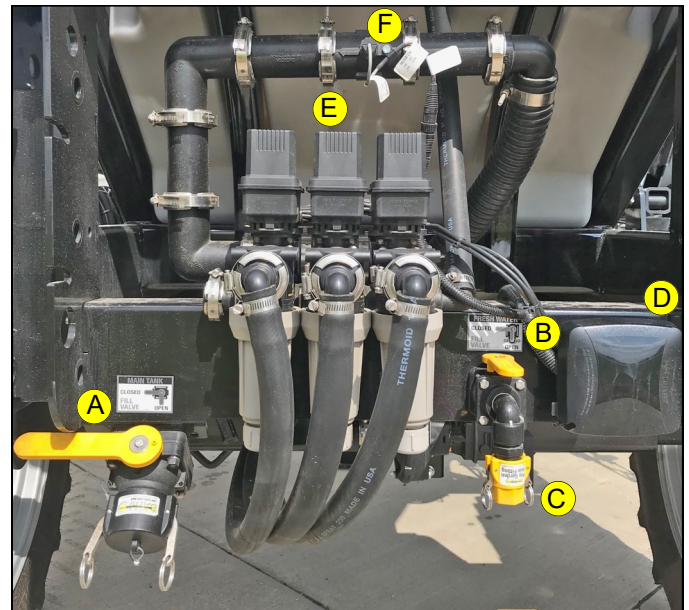

12. Plumbing (See Figure 6)

- A. Main Tank Fill Valve (2” Quick Fill)
- B. Rinse Tank Fill Valve (Garden Hose Fitting)
- C. PWM Control Pump (9306C-HM1C-BU-002)
- D. Electrical Junction Box
- E. Section Control Valves (450BEC-FB Series)
- F. Flow Meter (RFM60P)

440/450 RAVEN CONTROLLER WITH PWM SETUP

1. Install Raven 440 or 450 control console and hook up to sprayer (see instructions inside controller box).
2. Turn on control console.
When making selections/entering numbers, always be sure to press enter to save your settings.
3. Make the following selections when prompted:
 - Units US (Enter)
 - Speed sensor 2 "SP2" (Enter)
 - Valve type C-P "Closed PWM" (Enter)
4. Select Boom Cal "Raven 440, 1-3", "Raven 450, 1-5"
 - Enter number of inches covered for each section (not full width of boom).To find the number of inches covered, multiply the number of nozzles per section and the number of inches between nozzles. (Ex. Section one; 12 nozzles x 20 inch between nozzles =240 inches)
5. Select Speed Cal
 - Enter 783 (This is the cal number for a Garmin GPS Sensor).
6. Select Meter Cal-Enter the meter cal number which is printed on the tag for on your Flow Meter. (ex. 720)
7. Select Valve Cal
 - Enter 43 (This is only for use with the PWM controlled hydraulic pump).
8. Select Rate 1
 - Enter the number of gallons/acre you want to spray in Rate 1. (ex. 10.0)
9. Select Rate 2-Enter the number of gallons/acre you want to spray in Rate 2. (ex. 20.0)
10. Select DATA MENU
 - Scroll to PWM Frequency and enter 110.
11. Hold SELF TEST
 - This will scroll through all settings to make sure everything is entered.
 - If all cal numbers are entered, it will stop scrolling after a few seconds. (move to step 12.)
 - If any cal numbers have not yet been entered, it will keep scrolling. (If so, you will need to go back through your cal numbers and make sure they are all entered correctly.)
12. Turn the Flow Control to MAN for manual control, turn the Booms all to the off position and turn the master on.
13. Hold INC to build pressure. This will allow you to check any leaks and use your inductor tank (if applicable) while sitting. **BE AWARE NOT TO OVER PRESSURIZE SYSTEM**
14. TO SPRAY
 - Turn the Flow Control to Rate 1 or Rate 2 (preference).
 - The speed you need to travel is dependent on the rate at which you are spraying.

2630 JD RATE CONTROLLER WITH PWM SETUP

1. After hooking up all wiring between tractor and sprayer, turn the system on.
2. Make sure all nozzles are open with desired tips installed.
3. From the Menu, select Rate Controller
4. Setup your Implement type
 - Select Pull Behind Sprayer, enter a name and tank size.
5. Select the Setup Tab (right)
6. Select the Implement Tab (top)
 - Enter your boom width
 - Adjust the width of each section
 - Be sure to enter any Fence Row(s) if applicable
7. Select the System Tab (top)
 - Section Valve type – 3 wire
 - Constant Flow – no
 - Control Valve Type – PWM
8. Select PWM Setup
 - Control Valve Calibration – 2743
 - Coil Frequency – 110
 - High Limit – 100
 - Low Limit – 1
9. Select Calibrate PWM
 - Turn Master ON and press Start
 - Decrease if necessary to make sure Low limit is at or around 1 gal/min. Set Low Limit
 - Increase if necessary to make sure High limit is at or just below max pump rotation or 80 psi. Set High Limit and turn off Master.
 - If you return to PWM Setup it may show new numbers in the High Limit and Low Limit.
10. Setup your Flowmeter
 - Flowmeter Calibration – Enter the Flowmeter cal. number located on your flow meter.
 - Flowmeter Units – 10 Gal.
11. Select the Rates Tab (top)
 - Set your rates at gal/acre.
12. Select the Diagnostics Tab (right)
 - From the dropdown menu under the Tests tab, select Nozzle Flow Check
 - Enter your desired speed into the Test Speed
 - Enter your desired Gal/Acre into the Rate
 - Turn the Master on and press Start to test
(At this point you can see the system will adjust its self to run at the desired speed while you are not driving.)

BREAK-IN

Although there are no operational restrictions on the applicator when used for the first time, it is recommended that the following mechanical items be checked:

A. After operating for 1/2 hour

1. Re-torque all the wheel bolts.
2. Re-torque all other fasteners and hardware.
3. Check that all electrical connections are tight.
4. Check that no chemical or hydraulic lines are being pinched or crimped. Re-align as required.
5. Check that all nozzles are working properly. Clean or replace as required.
6. Lubricate all grease fittings.

B. After 5 hours and 10 hours of operation

1. Re-torque all wheel bolts, fasteners and hardware.
2. Check fertilizer and hydraulic line routing.
3. Check that all nozzles are working properly.
4. Then go to the normal servicing and maintenance schedule as defined in the Maintenance Section.
5. Lift right hand side of machine and check main wheel bearing for proper play (slight wobble when pulling on top of wheel). Repeat for left hand side.

SERVICE & MAINTENANCE

1. Review the Operator's Manual and all safety items before working with, maintaining or operating the applicator.
2. Place all controls in neutral, stop the tractor engine, turn monitor off, set park brake, remove ignition key, wait for nozzles to stop spraying before servicing, adjusting, repairing or unplugging.
3. Follow good shop practices:
 - Keep service area clean and dry
 - Be sure electrical outlets and tools are properly grounded
 - Use adequate light for the job at hand.
4. Before applying pressure to a hydraulic system, make sure all components are tight and that steel lines, hoses and coupling are in good condition.
5. Before applying pressure to fertilizer system, make sure that all connection are tight and that all hoses and fittings are in good condition.
6. Install wing lock pins and tower stops before relieving pressure from hydraulic circuit to service Applicator.
7. Keep hands, feet, clothing and hair away from all moving and/or rotating parts.
8. Clear the area of bystanders, especially children, when carrying out any maintenance and repairs or making any adjustments or filling.
9. Place stands or blocks under the frame before working beneath the machine.
10. Wear safety goggles, neoprene gloves and protective clothing when working on the Applicator filled with active chemical.
11. Wash machine to remove all chemical residue before working on unit. Wear appropriate protective gear at all times.
12. Protect yourself from chemical contamination.

PLACING IN STORAGE

At the end of the spray season, the machine should be thoroughly inspected and prepared for storage. Repair or replace any worn or damaged components to prevent any unnecessary down time at the beginning of the next season.

Follow this procedure:

1. Thoroughly wash the machine using a hose or a pressure washer to remove all dirt, mud, debris or residue.
2. Thoroughly wash the inside of the tank.
3. In climates that encounter freezing temperatures during the storage period, the following preparation should be done:
 - a. Add 10 gallons (40 liters) of a potable RV antifreeze to the tank.
 - b. Run unit for 5 minutes in the spray cycle to circulate solution to all parts of the circuit.
 - c. While circulating the fluid, open and close all the valves in the system to flush all the water from the system.
 - d. Flush the solution out the booms.
 - e. Open all disconnects and drain hoses, pumps, filters, solenoids and tanks.
4. Lubricate all grease points. Make sure all grease cavities have been filled with grease to remove any water residue from washing.
5. Inspect all the hydraulic hoses, couplers and fittings. Tighten any loose fittings. Replace any hose that is badly cut, nicked, abraded or is separating from the crimped end of a fitting.
6. Inspect all the spray hoses and fittings. Tighten any loose fittings. Replace any hose that is badly cut, nicked, abraded or is separating from a fitting.
7. Touch up all paint nicks and scratches to prevent rusting.

◆◆ STORAGE SAFETY ◆◆

1. Store unit in an area away from human activity.
2. Do not permit children to play on or around the stored applicator.
3. Unhook and store in the transport configuration.

REMOVING FROM STORAGE

When removing from storage and preparing to use, follow this procedure.

1. Clear the area of bystanders, especially small children, and remove foreign objects from the machine and the working area.
2. Check
 - a. Tank for cracks
 - b. Tank hold down hardware
 - c. All hardware. Tighten as required.
 - d. Tire pressure.
 - e. All sprayer and hydraulic lines, fittings and connections. Tighten as required.
3. Lubricate all grease fittings.
4. Replace any defective parts.
5. Fill the tank with 20 gallons (75 liters) of clean water and run for 5 minutes. Open and close all valves several times. Flush water through the booms.
6. Repeat step 5.
7. Calibrate the pump, nozzles and sprayer before using.
8. Go through the pre-field checklist before using.

GREASING

1. Wipe grease fitting with a clean cloth before greasing to prevent injecting dirt and grit into joint.
2. Replace and repair broken fittings immediately.
3. If a fitting will not take grease, remove and clean thoroughly. Also clean lubricant passageway. Replace fitting if necessary.

***Note: Grease 20 points 8 hours or daily. Along with 2 points per coulter. Hubs and spindles should be greased biannually.**

***Note: It is best to grease the machine at the end of the day to ensure that fertilizer/chemicals do not have time to start corroding parts.**

L/R GREASE LOCATIONS

Apply adequate grease to the following:

1. L/R Main Wing Hinge (Figure 10b)
2. L/R Flip Wing (35') (Figure 10c)
3. Coulter Pivots (Figure 10d)
4. Parallel Hinge Bushings (Figure 10a)
5. Piston Pump (Refer to pump operators manual)

Figure 10a

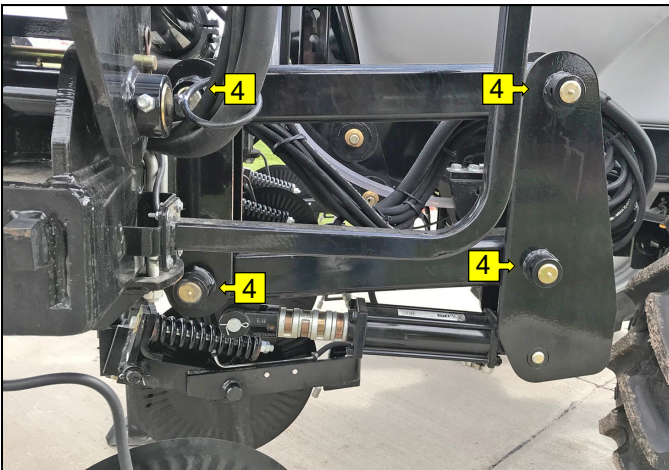

Figure 10b



Figure 10c

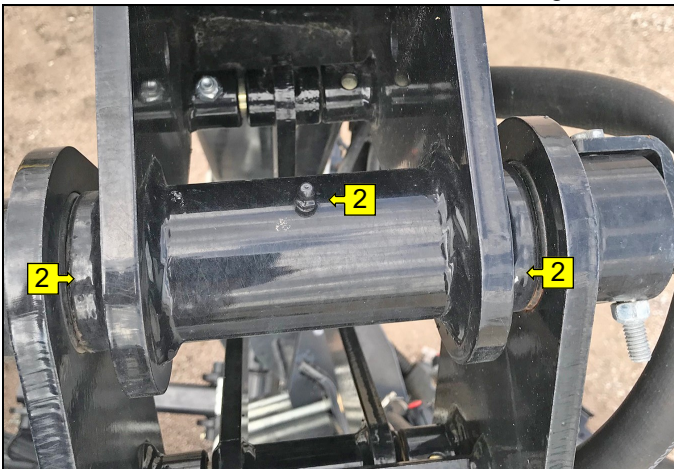
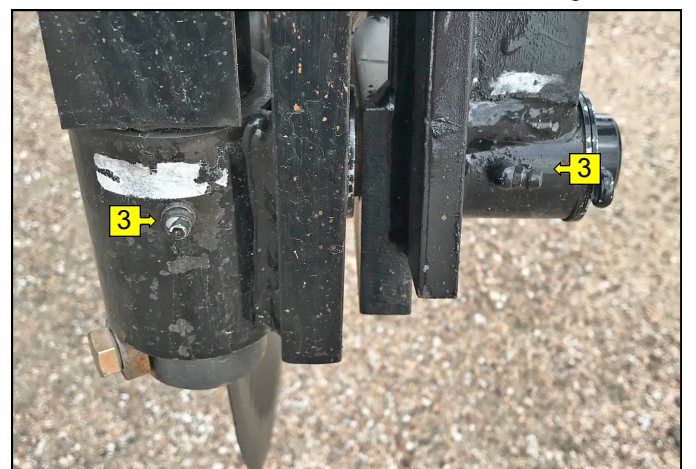
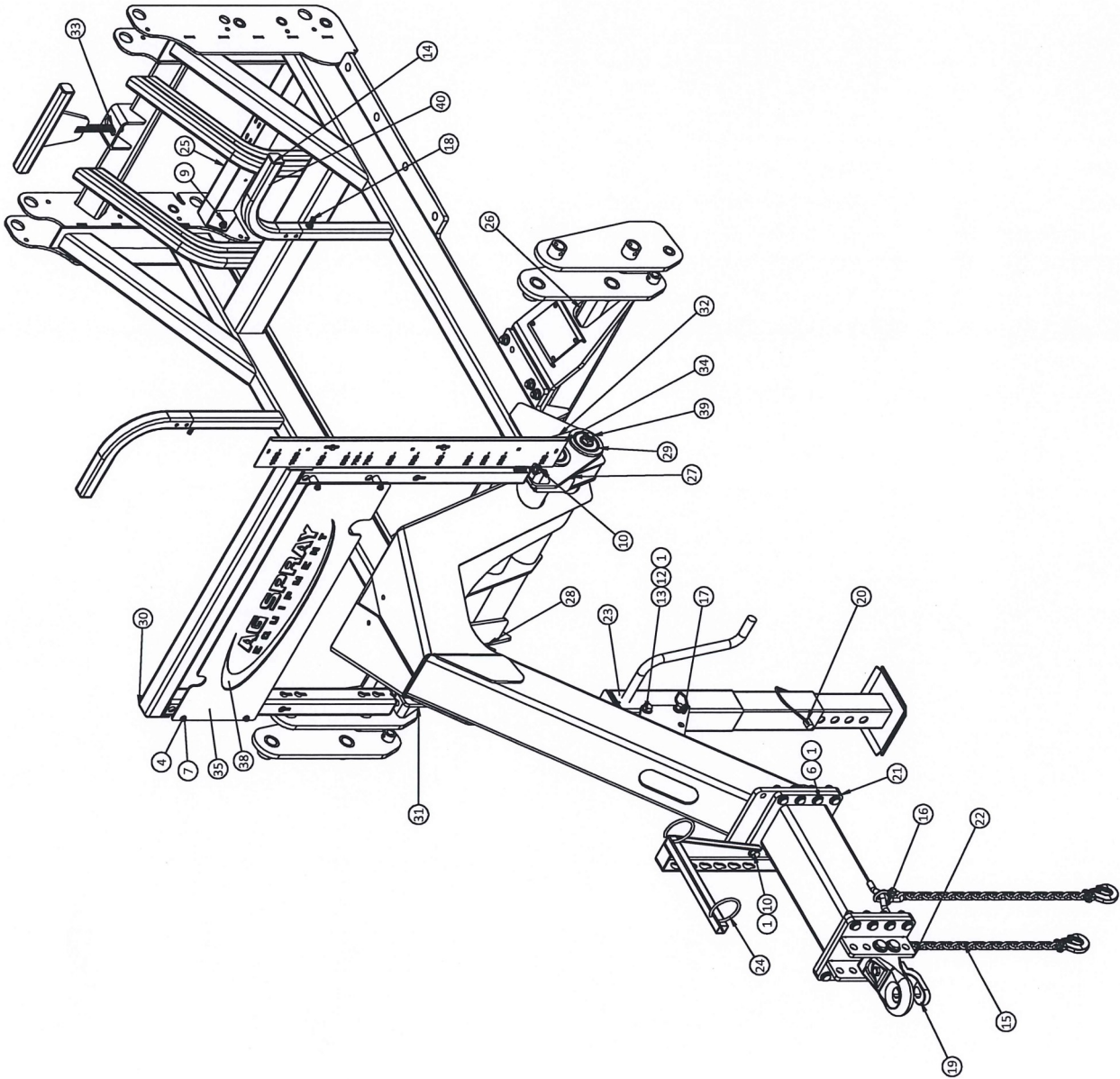

Figure 10d



APPLICATOR FRAME



PARTS LIST			
No.	Part #	Qty.	Part Description
1	5006359	23	3/4-10nc Hex Flanged Toplock Nut Gr. 8
2	5006363	6	1"-8nc Hex Flanged Toplock Nut Gr. 8
3	5006365	4	1/2-13nc Hex Flanged Toplock Nut Gr. 8
4	5006366	8	3/8"-16nc Hex Flanged Toplock Nut Gr. 8
5	5034482	2	3/8"-16nc x 1" Carriage Bolt
6	5034510	20	H.H.C.S. 3/4"-10 x 2-1/2"
7	5034544	4	3/8"-16nc x 2-1/2" Carriage Bolt (Full Thread)
8	5034547	2	H.H.C.S. 1"-8nc x 6-1/2"
9	5034692	4	H.H.C.S. Flanged 1/2"-13nc x 1-1/2"
10	5034755	4	Fling HH Bolt 3/4"-10 x 3 1/2"
11	5034764	2	Fling HH Bolt 3/8"-16 x 1"
12	5034801	1	3/4-10 x 7 Fling Frame Bit
13	5041094	2	Machinery Bushing, 3/4" ID x 1-1/4" OD
14	5046445	2	Tube Cap, 2x2x3/16" Wall
15	5049042	2	Safety Chain, 3/8" x 37" w/.4375" Clevis Hook
16	5052019	2	1/2" Safety Anchor Shackles w/Screw Pin
17	5101327	1	Hitch Pin
18	5117104	2	1/2-13 x 1-1/2" Square Head Cup Point Set Screw
19	5274832	1	Cast Hitch
20	5275427	1	Jack
21	5277462	1	Tongue Extension Weldment
22	5277463	1	Bolt-On Hitch Weldment
23	5277467	1	LA5000 Jack Swing Tube Weldment
24	5277636	1	Hose Guide Weldment LA5000
25	5278725	1	Valve Mounting Bracket
26	5279268	1	1050 Fixed Position Liftarm Weldment
27	5279273	1	Small Frame Weldment
28	5279278	1	Small Gooseneck Main Frame Weldment
29	5279372	4	Applicator Gooseneck Attach Pin Weldment
30	5279378	1	1050 Tank Hold Down Weldment
31	5279383	1	1050 Tank Hold Down Attach Weldment (RH)
32	5279384	1	1050 Tank Hold Down Attach Weldment (LH)
33	5279386	1	Small Frame Rear Adj. Tank Hold Down Weldment
34	5280023	1	1050 Sight Gauge Angle w/Graduations
35	5280501	1	1050 Hand Rinse Tank Hold Down Weldment
36	5280573	4	Spacer Hand Rinse Tank Tube
37	5280584	2	Sight Gauge Upper Mount Bracket
38	5280588	1	1050 Hand Rinse Tank Hold Down Backing Widmin
39	5280803	2	Large Sprayer Gooseneck Attach Weldment
40	5280885	2	Tank Support Weldment

5280890 - 27' SINGLE TUBE APPLICATOR

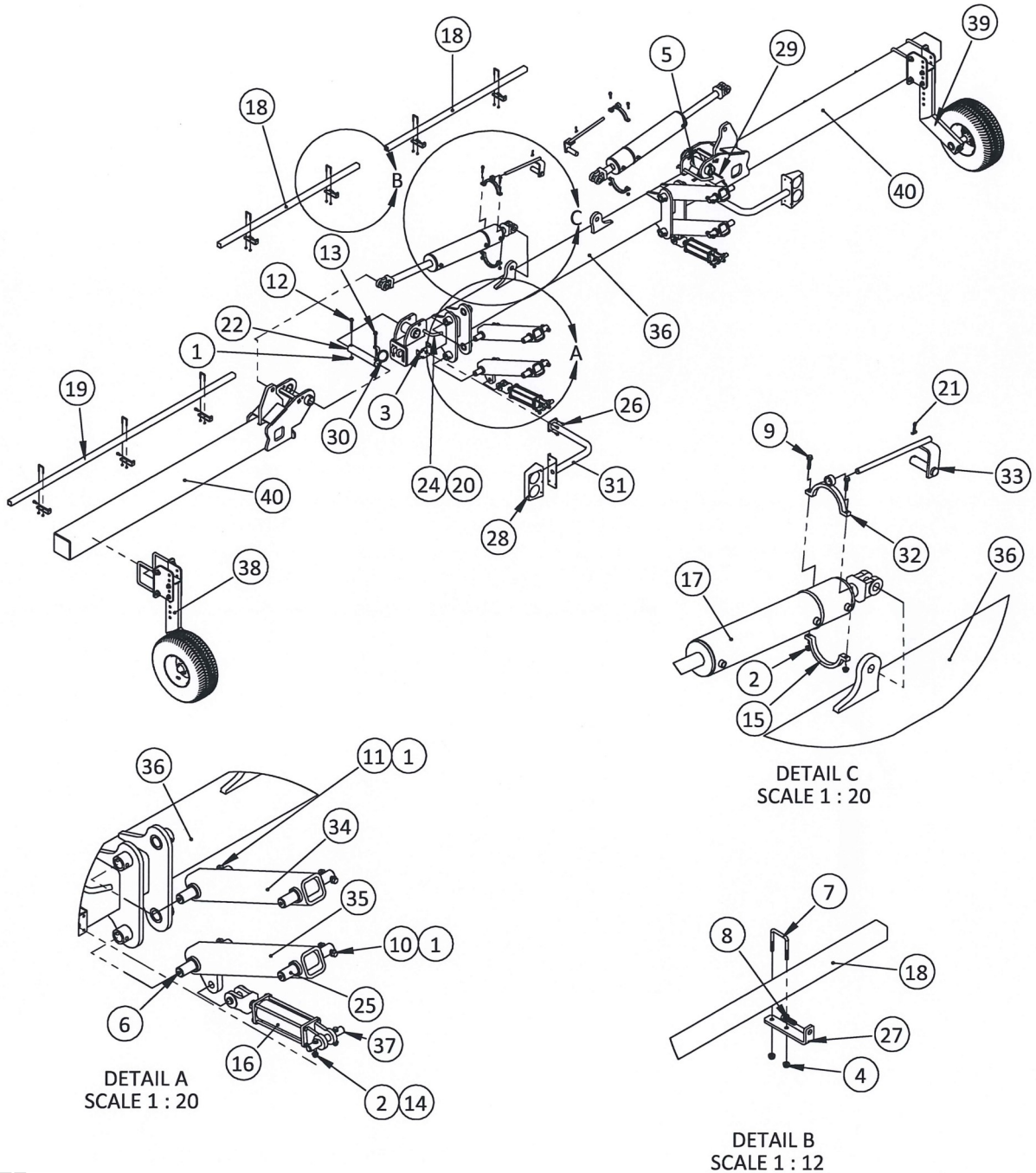

NOTE:

This Toolbar is compatible with the following
Applicator Frames:

5280827

5280879

PARTS LIST			
No.	Part #	Qty.	Part Description
1	5006365	12	1/2-13nc Hex Flanged Toplock Nut Gr. 8
2	5006366	8	3/8"-16nc Hex Flanged Toplock Nut Gr. 8
3	5006367	8	5/16-18nc Hex Flanged Toplock Nut Gr. 8
4	5006386	20	Fling Head Lock Nut, 1/4"-20
5	5012015	2	Grease Zerk, 1/4"-28 Thread
6	5012016	8	Grease Zerk, 1/8"-27 nptThread
7	5034473	10	Square U-Bolt, 1/4" x 1-9/16" x 2-1/8"
8	5034597	10	3/8-16nc Hex Head Self-Tap Screw, Gr. 2
9	5034664	4	H.H.C.S. Flanged 3/8"-16nc x 1-3/4"
10	5034697	4	HHCS Flanged 1/2"-13nc x 2-3/4"
11	5034698	4	HHCS Flanged 1/2"-13nc x 3"
12	5034701	2	HHCS Flanged 1/2"-13nc x 3-3/4"
13	5034702	2	HHCS Flanged 1/2"-13nc x 4"
14	5034775	4	Fling HH Bolt 3/8"-16 x 2-1/2"
15	5051148	2	Anti-Rotation Clamp
16	5061037	2	Hydraulic Cylinder, 3" x 8", 1.25" Rod
17	5061049	2	Hydraulic Cylinder, 5" Bore x 18.00/2.00 Stroke
18	5100705	2	Nozzle Tube (59-3/4")
19	5100706	2	Nozzle Tube (96")
20	5101065	2	#211 Hitch Pin Clip
21	5101230	2	Cotter Pin, 3/16" x 2"
22	5101315	2	Inner Wing Pivot Pin
23	5101318	1	Linkage Pivot Pin
24	5101322	2	Bent Pin, 3/4" Dia. X 9-1/4" Usable Length
25	5101342	8	Small Toolbar Liftarm Pin
26	5117323	8	HHCS Flanged 5/16"-18 x 3/4"
27	5133256	10	Hose Deflector Strap (Long)
28	5274831	2	Warning Light
29	5275468	1	Short Hose Guide Weldment (RH)
30	5275469	1	Short Hose Guide Weldment (LH)
31	5277391	2	Light Mount Weldment
32	5278161	2	Anti-Rotation Cylinder Mount Weldment
33	5278162	2	Anti-Rotation Pin Weldment
34	5278738	2	Small Upper Liftarm Weldment
35	5278739	2	Small Lower Liftarm Weldment
36	5278780	1	Small Toolbar Center Weldment
37	5279882	2	Small Frame Liftarm Connect Pin
38	5280886	1	Gauge Wheel for 7 x 7 Tube Assembly (RH)
39	5280886	1	Gauge Wheel for 7 x 7 Tube Assembly (LH)
40	5280889	2	27' Toolbar Outer Weldment

5280891 - 30' SINGLE TUBE APPLICATOR

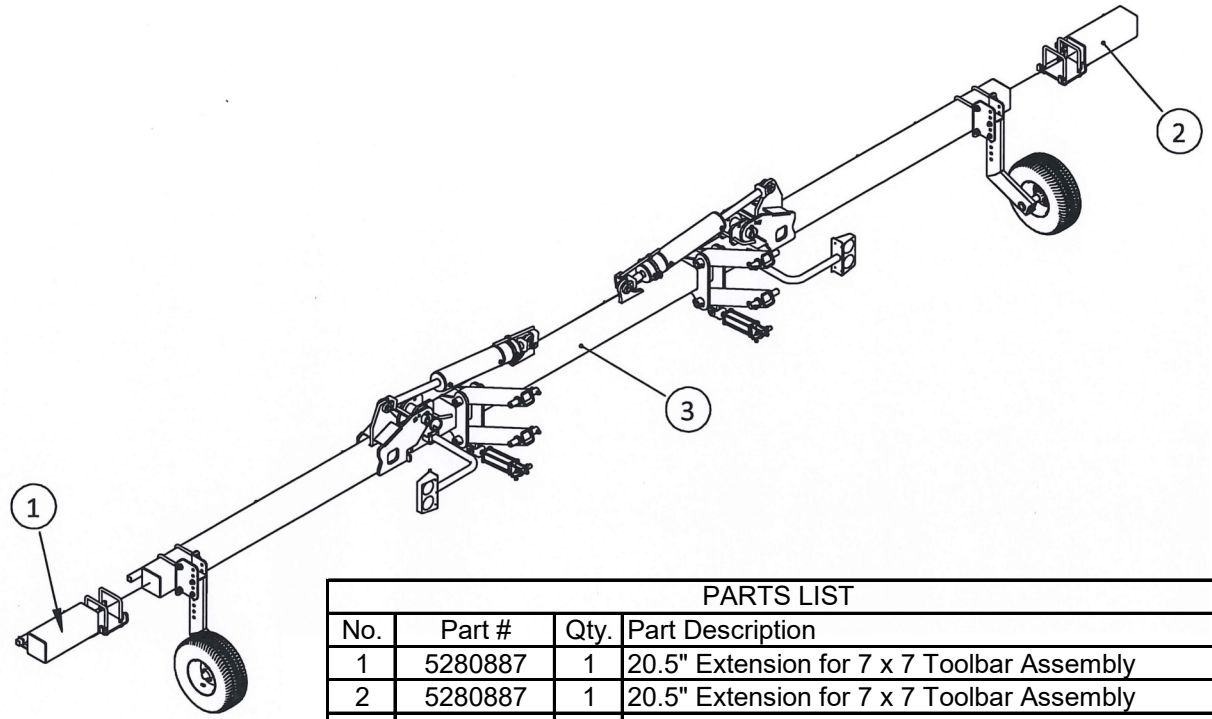

PARTS LIST			
No.	Part #	Qty.	Part Description
1	5280887	1	20.5" Extension for 7 x 7 Toolbar Assembly
2	5280887	1	20.5" Extension for 7 x 7 Toolbar Assembly
3	5280890	1	27' Single Bar, Single Fold Toolbar

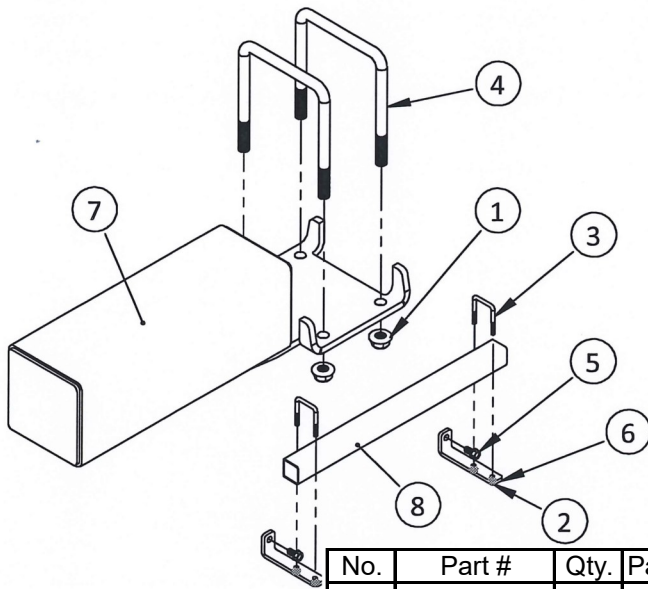

No.	Part #	Qty.	Part Description
1	5006359	4	3/4-10nc Hex Flanged Toplock Nut Gr. 8
2	5006386	4	Fling Head Lock Nut, 1/4"-20
3	5034473	2	Square U-Bolt, 1/4" x 1-9/16" x 2-1/8"
4	5034589	2	Square U-Bolt, 3/4" x 7-1/8" x 8-1/2"
5	5034597	2	3/4"-16 x 3/4" Self Tapping Screw
6	5133256	2	Hose Deflector Strap (Long)
7	5280181	1	Extension Outer Toolbar Weldment
8	5280613	1	Nozzle Tube (20")

NOTE:

This Toolbar is compatible with the following
Applicator Frames:

- 5280827
- 5280879

5279129 - 40' SINGLE TUBE APPLICATOR

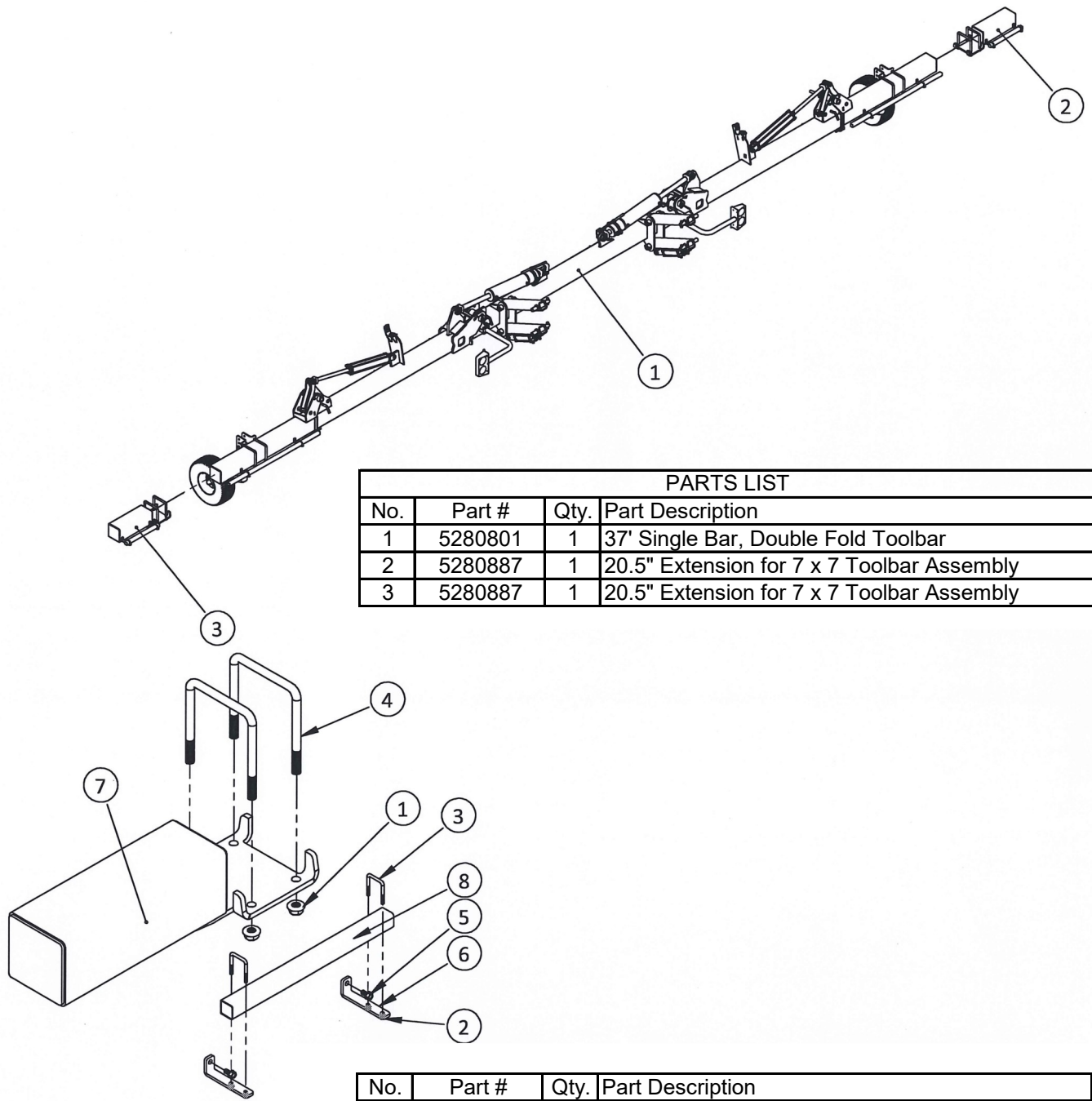

PARTS LIST			
No.	Part #	Qty.	Part Description
1	5280801	1	37' Single Bar, Double Fold Toolbar
2	5280887	1	20.5" Extension for 7 x 7 Toolbar Assembly
3	5280887	1	20.5" Extension for 7 x 7 Toolbar Assembly

No.	Part #	Qty.	Part Description
1	5006359	4	3/4-10nc Hex Flanged Toplock Nut Gr. 8
2	5006386	4	Flng Head Lock Nut, 1/4"-20
3	5034473	2	Square U-Bolt, 1/4" x 1-9/16" x 2-1/8"
4	5034589	2	Square U-Bolt, 3/4" x 7-1/8" x 8-1/2"
5	5034597	2	3/4"-16 x 3/4" Self Tapping Screw
6	5133256	2	Hose Deflector Strap (Long)
7	5280181	1	Extension Outer Toolbar Weldment
8	5280613	1	Nozzle Tube (20")

NOTE:

This Toolbar is compatible with the following
Applicator Frames:

5280827

5280879

5280801 - 37' SINGLE TUBE APPLICATOR

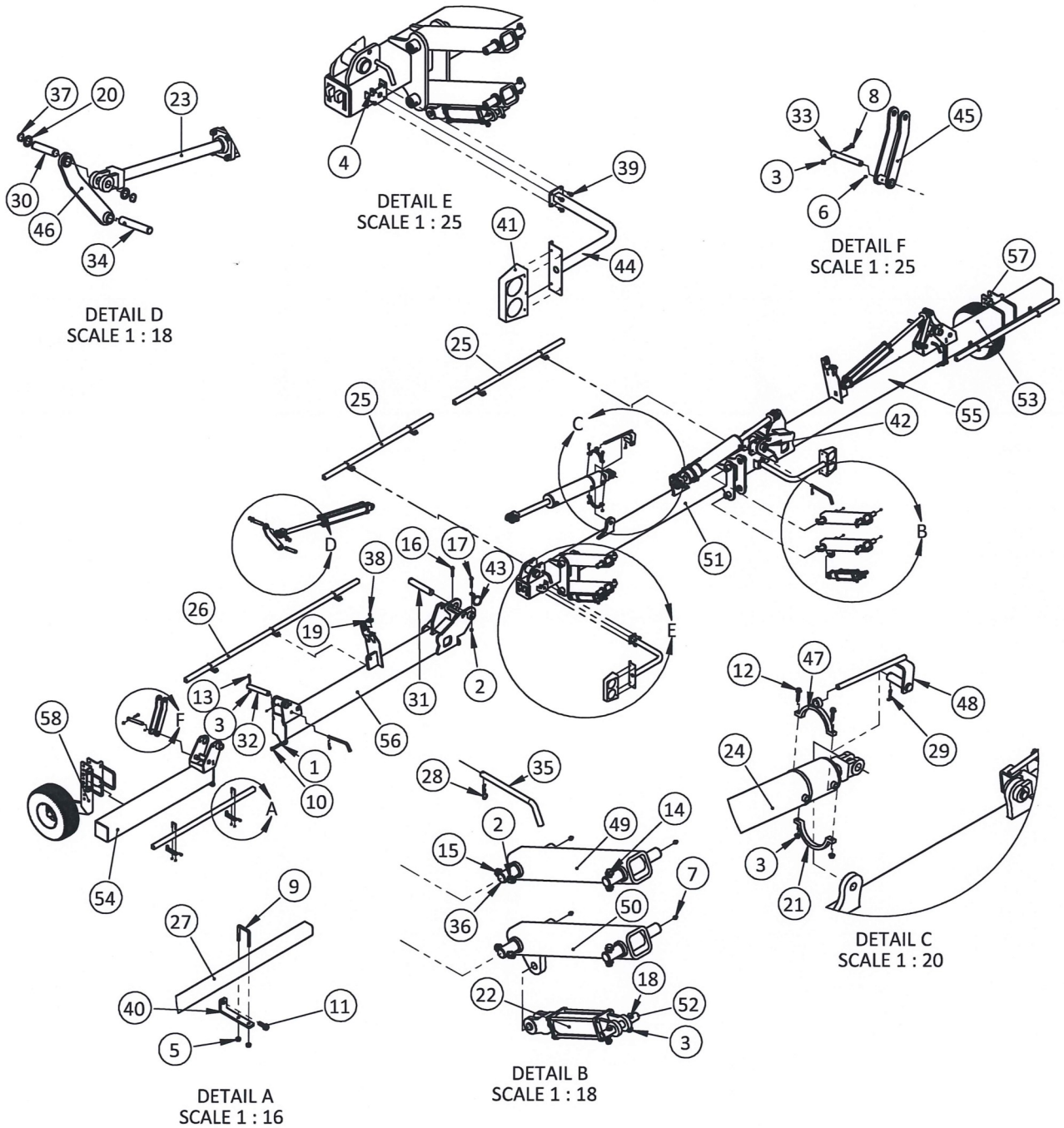

NOTE:

This Toolbar is compatible with the following
Applicator Frames:

5280827

5280879

5280801 - 37' SINGLE TUBE APPLICATOR

PARTS LIST			
No.	Part #	Qty.	Part Description
1	5006260	2	3/4"-10 Hex Jam Nut
2	5006365	12	1/2"-13nc Hex Flanged Toplock Nut Gr. 8
3	5006366	14	3/8"-16nc Hex Flanged Toplock Nut Gr. 8
4	5006367	12	5/16"-18nc Hex Flanged Toplock Nut Gr. 8
5	5006386	28	Fing Head Lock Nut, 1/4"-20
6	5012015	6	Grease Zerk, 1/4"-28 Thread
7	5012016	8	Grease Zerk, 1/8"-27 nptThread
8	5034087	4	H.H.C.S. 3/8"-16nc x 2"
9	5034473	14	Square U-Bolt, 1/4" x 1-9/16" x 2-1/8"
10	5034594	2	H.H.C.S. 3/4"-10nc x 3-1/2" (Full Thread)
11	5034597	14	3/8"-16nc Hex Head Self-Tap Screw, Gr. 2
12	5034664	4	H.H.C.S. Flanged 3/8"-16nc x 1-3/4"
13	5034669	2	H.H.C.S. Flanged 3/8"-16nc x 3"
14	5034697	4	H.H.C.S. Flanged 1/2"-16nc x 2-3/4"
15	5034698	4	H.H.C.S. Flanged 1/2"-16nc x 3"
16	5034701	2	H.H.C.S. Flanged 1/2"-13nc x 3-3/4"
17	5034702	2	H.H.C.S. Flanged 1/2"-13nc x 4"
18	5034775	4	Fing HH Bolt 3/8"-16 x 2-1/2"
19	5040015	4	Bumper
20	5041113	4	Machinery Bushing, 1-1/2" OD x 1" ID x 10 Ga.
21	5051148	2	Anti-Rotation Clamp
22	5061037	2	Hydraulic Cylinder, 3" x 8", 1.25" Rod
23	5061048	2	Hydraulic Cylinder, 3" x 20", 1.5" Rod
24	5061049	2	Hydraulic Cylinder, 5" Bore x 18.00/2.00 Stroke
25	5100705	2	Nozzle Tube (59-3/4")
26	5100706	2	Nozzle Tube (96")
27	5100707	2	Nozzle Tube (56")
28	5101065	4	#211 Hitch Pin Clip
29	5101230	2	Cotter Pin, 3/16" x 2"
30	5101256	2	Front Cylinder Pin
31	5101315	2	Inner Wing Pivot Pin
32	5101316	2	Outer Wing Pivot Pin
33	5101317	2	Linkage Pivot Pin
34	5101318	2	Linkage Pivot Pin
35	5101322	4	Bent Pin, 3/4" Dia. X 9-1/4" Usable Length
36	5101342	8	Small Toolbar Liftarm Pin
37	5110316	4	External Snap Ring, 1"
38	5117300	4	HHCS Flanged 5/16"-18nc x 1"
39	5117323	8	HHCS Flanged 5-16"-18nc x 3/4"
40	5133256	14	Hose Deflector Strap (Long)
41	5274831	2	Warning Light
42	5275468	1	Short Hose Guide Weldment (RH)
43	5275469	1	Short Hose Guide Weldment (LH)
44	5277391	2	Light Mount Weldment
45	5277392	2	Link Arm Double Weldment
46	5277393	2	Link Arm Weldment
47	5278161	2	Anti-Rotation Cylinder Mount Weldment
48	5278162	2	Anti-Rotation Pin Weldment
49	5278738	2	Small Upper Liftarm Weldment
50	5278739	2	Small Lower Liftarm Weldment
51	5278780	1	Small Toolbar Center Weldment
52	5279882	2	Small Frame Liftarm Connect Pin
53	5280182	1	Outer Toolbar Weldment (RH)
54	5280185	1	Outer Toolbar Weldment (LH)
55	5280188	1	Middle Toolbar Weldment (RH)
56	5280189	1	Middle Toolbar Weldment (LH)
57	5280886	1	Gauge Wheel for 7 x 7 Tube Assembly (RH)
58	5280886	1	Gauge Wheel for 7 x 7 Tube Assembly (LH)

5279145 - SMALL FRAME NARROW SINGLE AXLE ASSEMBLY

PARTS LIST			
No.	Part #	Qty.	Part Description
1	5006359	4	3/4-10nc Hex Flanged Toplock Nut Gr. 8
2	5006363	4	1"-8nc Hex Flanged Toplock Nut Gr. 8
3	5034742	4	Fling HH Bolt 3/4"-10 x 8"
4	5034750	4	Fling HH Bolt 1-8 x 3"
5	5085016	2	Hub Assembly (758) (8-Bolt)
6	5279368	1	Small Axle Center Short Weldment
7	5279370	2	Small Axle Short Weldment (RH)

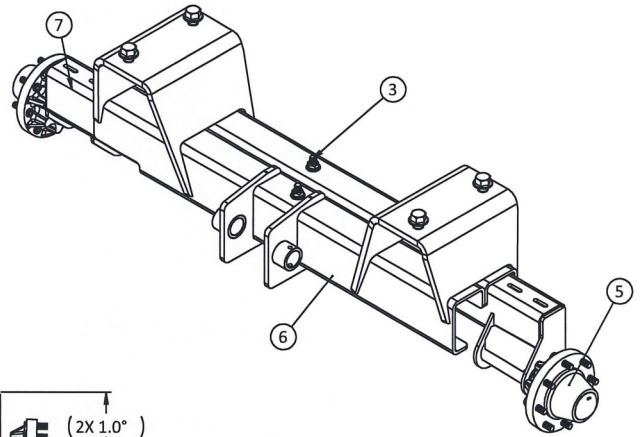
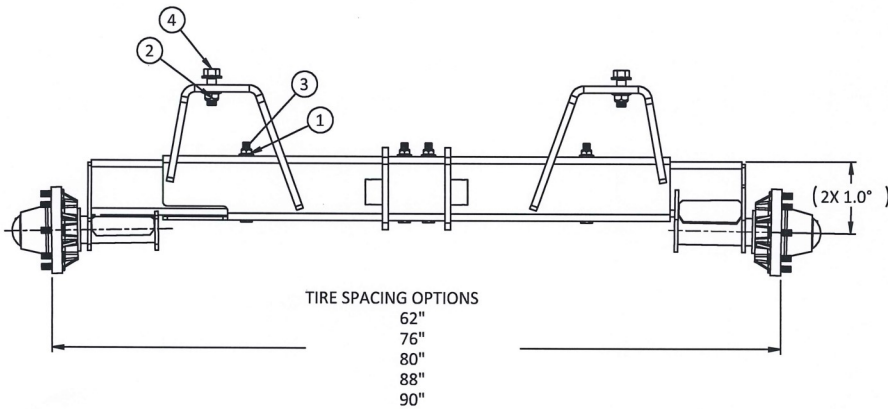

5279143 - SMALL FRAME WIDE SINGLE AXLE ASSEMBLY

PARTS LIST			
No.	Part #	Qty.	Part Description
1	5006359	4	3/4-10nc Hex Flanged Toplock Nut Gr. 8
2	5006363	4	1"-8nc Hex Flanged Toplock Nut Gr. 8
3	5034742	4	Fling HH Bolt 3/4"-10 x 8"
4	5034750	4	Fling HH Bolt 1-8 x 3"
5	5085016	2	Hub Assembly (758) (8-Bolt)
6	5279355	1	Small Axle Center Weldment
7	5279357	2	Small Axle Weldment (RH)

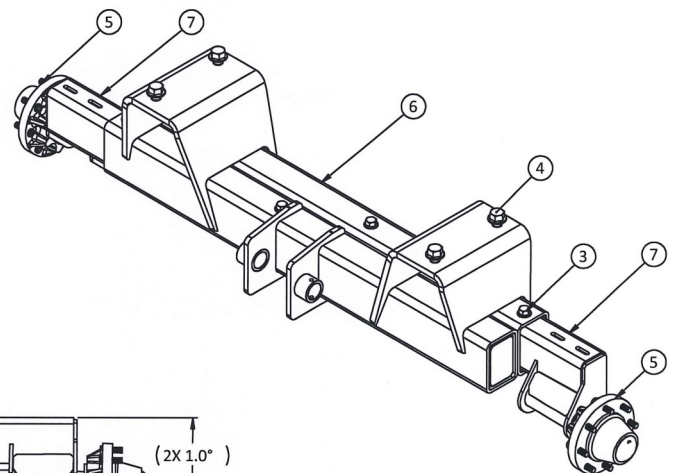
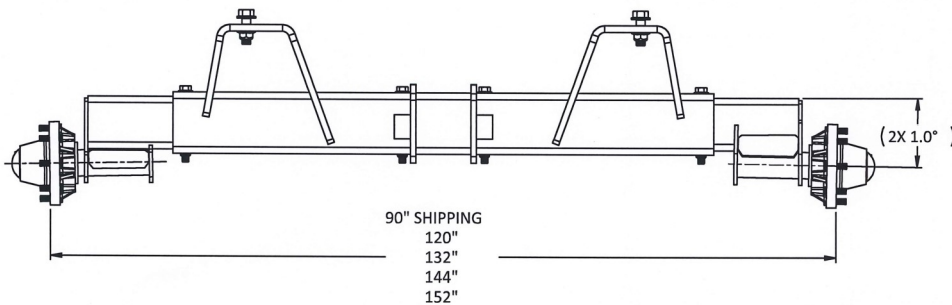

5085016 - HUB ASSEMBLY FOR SHORT & LONG AXLE

No.	Part #	Qty.	Part Description
1	"758" Hub	1	Hub
2	5031149	1	Cone Bearing
3	5031152	1	Inner Cone Bearing
4	5031170	1	Inner Race
5	5046366	1	Hub Cap
6	5072498	1	Grease Seal (for 758 Hub)
7	P151407	8	Stud Bolt, 5/8"-18 UNF
8	P702217	1	Inner Race

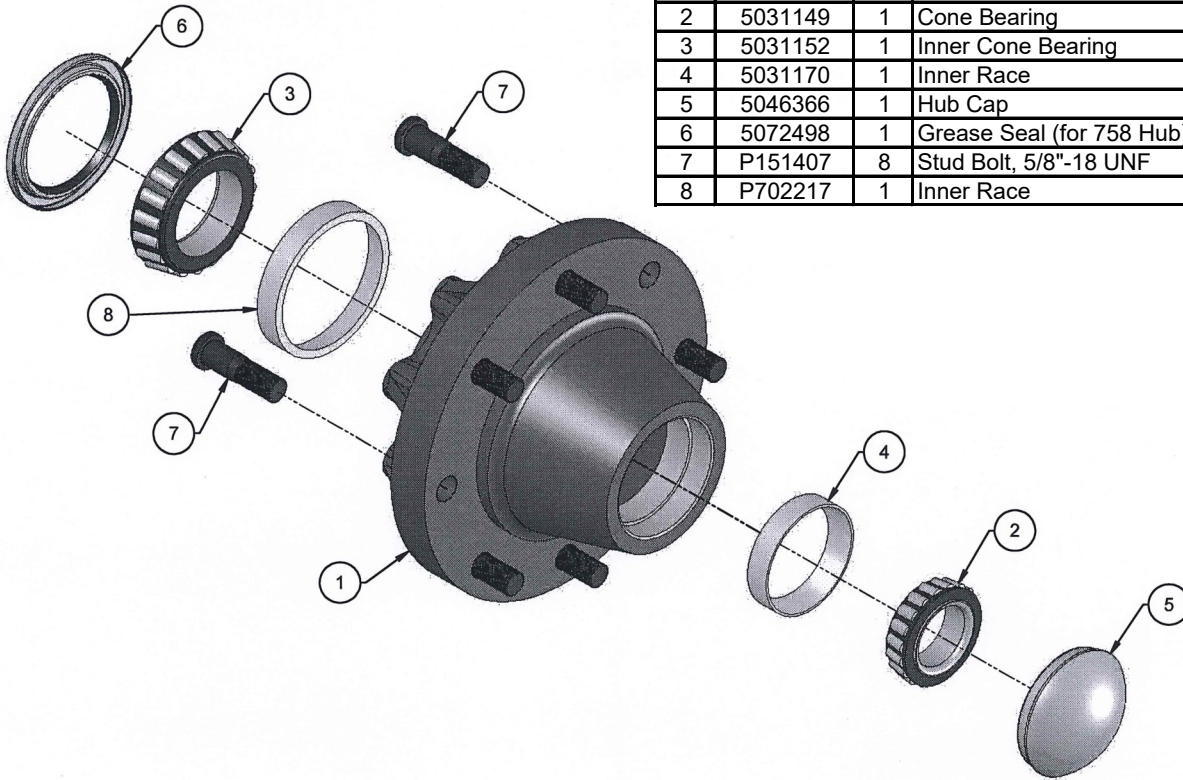

RFM 60 P Flowmeter Replacement Parts 063-0171-793

No.	Raven Part #	Part Description
1	106-0159-514	Body, RFM 60 P Flowmeter
2	063-0171-673	Rotor/Magnet Assembly
3	063-0171-674	Hub/Bearing Assembly, Upstream
4	063-0171-769	Hub Assembly, Downstream
5	335-0000-278	Ring, Retaining, Internal
6	063-0173-062	Stud Bearing
7	435-3002-017	Clamp, Cable
8	310-0002-137	Screw, Thread Forming
9	063-0171-669	Sensor, Assembly, External

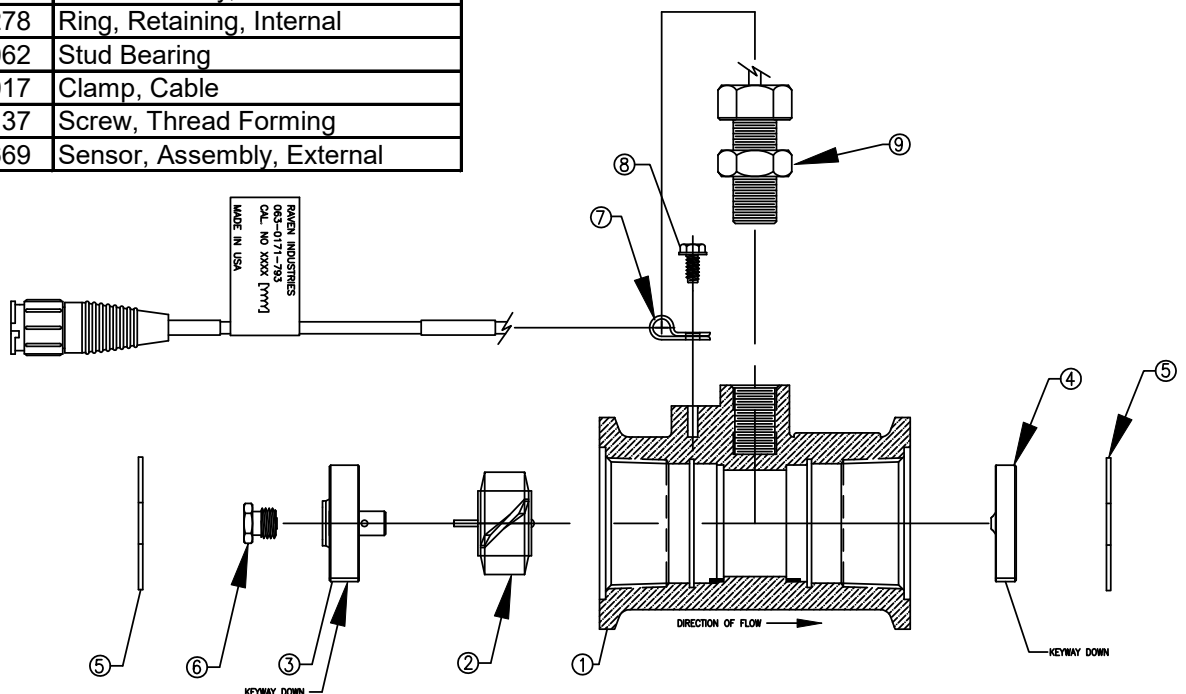

5280054 - WHEEL DRIVE PUMP

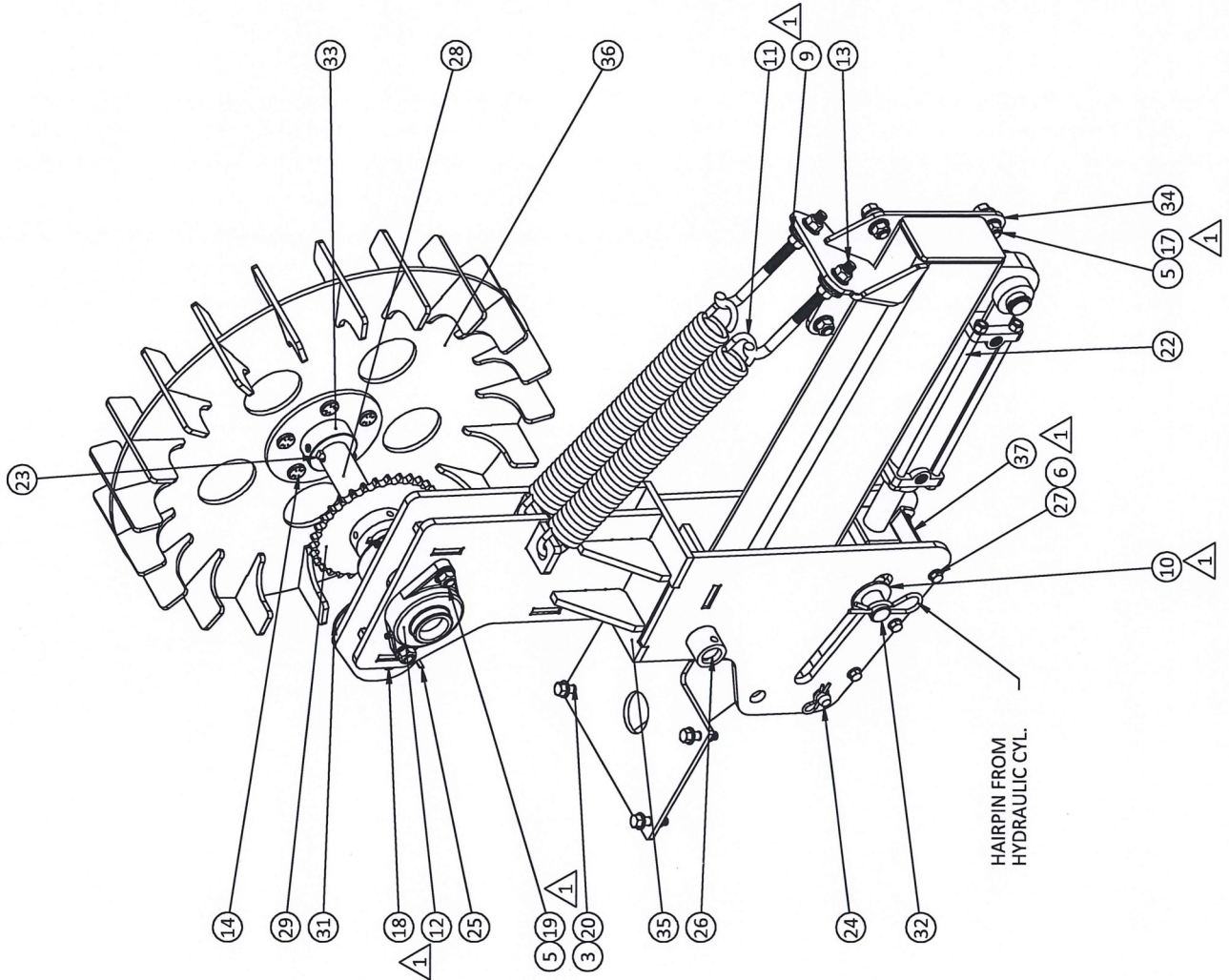

PARTS LIST			
No.	Part #	Qty.	Part Description
1	5006035	1	5/16"-18 Hex Locknut
2	5006092	1	3/8"-16 Hex Locknut
3	5006259	4	3/8"-16 Hex Whizz (Flange) Locknut
4	5006301	5	1/2"-20 Hex Cone Wheel Nut
5	5006365	12	1/2"-13nc Hex Flanged Toplock Nut Gr. 8
6	5006367	6	5/16"-18nc Hex Flanged Toplock Nut Gr. 8
7	5012015	1	Grease Zerk, 1/4"-28 Thread
8	5016030	5	Flatwasher, 3/8"
9	5016031	8	Flatwasher, 1/2"
10	5016190	4	Flatwasher, 1"
11	5019265	2	Extension Spring
12	5031174	2	2-Bolt Flanged Ball Bearing (for 1.438" Shaft)
13	5034111	2	1/2" x 6" Hook Bolt
14	5034540	5	Serrated Shoulder Bolt, 1/2"-20 N.F. x 1-1/8"
15	5034640	1	HHCS Flanged 5/16"-18nc x 2"
16	5034666	1	HHCS Flanged 3/8"-16nc x 2-1/4"
17	5034691	4	HHCS Flanged 1/2"-13nc x 1-1/4"
18	5034697	1	HHCS Flanged 1/2"-13nc x 2-3/4"
19	5034761	4	Fing HH Bolt 1/2-13 x 1-1/2
20	5034763	4	Fing HH Bolt 3/8-16 x 1-1/2
21	5041153	2	Bushing
22	5061035	1	Hydraulic Cylinder, 2" x 6" x 1.125" Rod
23	5089054	2	3/8" Square Key x 1-3/4"
24	5101226	1	Hitch Pin, 5/8" Dia., 4-1/4" Useable w/Hairpin Cotter
25	5101230	1	Cotter Pin, 3/16" x 2"
26	2101282	1	Pump Pivot Pin
27	5117323	6	HHCS Flanged 5-16"-18nc x 3/4"
28	5118193	1	Pump Drive Shaft
29	5130014	1	Sprocket (50B32) (1-7/16 Keyway)
30	5130015	1	15-Tooth Sprocket
31	5275325	1	#50 Spring Loaded Rotary Chain Tensioner
32	5275425	1	Lift Arm Cylinder Pin Weldment
33	5275436	1	Wheel Hub Weldment
34	5280042	1	Pump Pivot Weldment
35	5280043	1	Rocker Arm Weldment
36	5280044	1	Steel Ground Drive Wheel Weldment
37	5280628	1	Rocker Arm Spacer Flat Weldment

PL450BEC-FB - Electric Shut-Off Flow Back Ball Valve Manifold

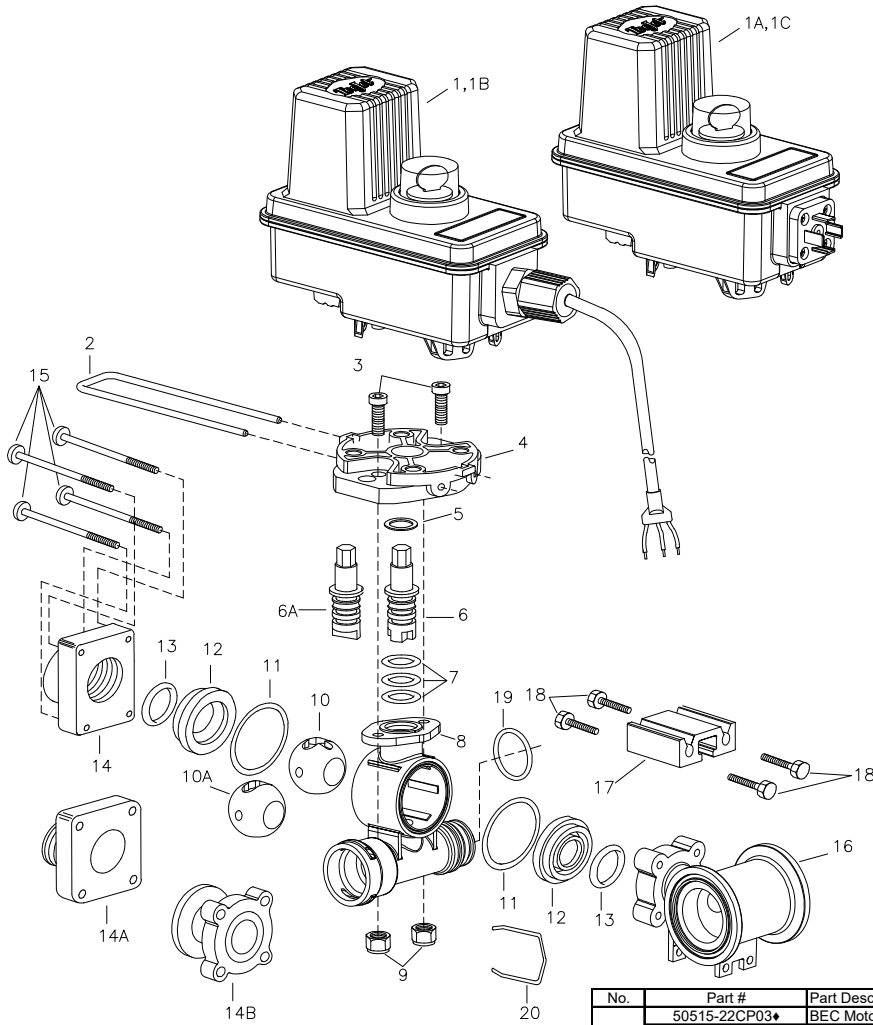

No.	Part #	Part Description
1	50515-22CP03♦	BEC Motor, 22-RPM (0.7-Sec.), 0.3-Meter Cable, Positively Switched
	50515-22CP05♦	BEC Motor, 22-RPM (0.7-Sec.), 0.5-Meter Cable, Positively Switched
	50515-22CP15♦	BEC Motor, 22-RPM (0.7-Sec.), 1.5-Meter Cable, Positively Switched
	50515-22CP60♦	BEC Motor, 22-RPM (0.7-Sec.), 6.0-Meter Cable, Positively Switched
1A	50515-22DP♦	BEC Motor, 22-RPM (0.7-Sec.), Din Connection, Positively Switched
1B	50533-22C03	BEC Motor, 22-RPM (0.7-Sec.), 0.3-Meter Cable
	50533-22C05	BEC Motor, 22-RPM (0.7-Sec.), 0.5-Meter Cable
	50533-22C15	BEC Motor, 22-RPM (0.7-Sec.), 1.5-Meter Cable
	50533-22C60	BEC Motor, 22-RPM (0.7-Sec.), 6.0-Meter Cable
1C	50533-22D	BEC Motor, 22-RPM (0.7-Sec.), Din Connection
2	CP50517-SSPV	Retaining Clip, 304 Stainless Steel
3	CP26197-7/8-SS	Socket Head Cap Screw, 1/4"-20 x 7/8", Stainless Steel (2 Req'd)
4	CP50514-PP	Motor Adapter, Polypropylene (Black)
5	CP20125-TEF	Thrust Washer, Teflon
6	CP56613-SS	Stem, 303 Stainless Steel (for Polypropylene Ball)
6a	CP56615-SS	Stem, 303 Stainless Steel (for Stainless Steel Ball)
7	CP7717-M12X-2.5-VI	O-Ring, Viton (3 Req'd)
8	CP55223-NYB	Flow Back Body, Nylon (Black)
9	CP38435-1/4-SSNY	Elastic Locknut, 1/4"-20, Stainless Steel (2 Req'd)
10	CP20106-2-PP	Flow Back Ball, Polypropylene (White)
10A	CP19926-2-SS	Flow Back Ball, 303 Stainless Steel
11	CP20564-VI	Gasket, Viton (2 Req'd)
12	CP20103-TEF	Seal, Teflon (2 Req'd)
13	CP7717-2-213-VI	O-Ring, Viton (2 Req'd)
14	CP20104-3/4-NYB	End Cap, Nylon (Black) (3/4" NPT Thread)
	CPB20104-3/4-NYB	End Cap, Nylon (Black) (3/4" BSPT Thread)
	CP20104-1-NYB	End Cap, Nylon (Black) (1" NPT Thread)
14A	CPB20104-1-NYB	End Cap, Nylon (Black) (1" BSPT Thread)
	CP45514-NYB	End Cap, Nylon (Black) (Quick Connect)
14B	CP45253-NYB	End Cap, Nylon (Black) (50-Series Flange)
15	CP45252-2-3/4-SSPV	Screw, 1/4"-12 x 2-3/4" Pan Head, Stainless Steel (4 Req'd)
16	CP55224-PP	#75 Narrow Tee Body, Polypropylene (Black)
17	CP45216-AL	Mounting Rail, Aluminum
18	CP45259-SS	Screw, M6 x 1 x 16MM Hex, Stainless Steel (4 Req'd)
19	CP7717-M25X3-VI	O-Ring, Viton
20	CP37166-1-302SS	Quick Connect Retaining Clip, 302 Stainless Steel
	56609-3FB-	Valve Body Sub-Assy, Specify Outlet Size & Ball Material (Includes Items 3-19)
AB344AE-KIT, Spare Parts Kit (Includes All Items Marked with *)		

NOTE: (B) in Part Number Indicates B.S.P.T. Inlet & Outlet Connections

♦ NOTE: For Negatively Switched Motors Specify "N" rather than "P" in Motor Part Number (Ex: 50515-22CN0)

NOTE: For Quick Connect Fitting Part Numbers - See Parts List PL45529

Teflon® is a Trademark of Dupont Company

Viton® is a Trademark of Dupont Dow Elastomers

COULTER ASSEMBLY

PARTS LIST			
No.	Part #	Qty.	Part Description
1	KSC-466360-RP716	2	Spring Pin, 7/16" x 3"
2	KSC-466315 (20" & 24")	1	Coulter Shaft
3	KSC-466320	1	Coulter Pivot Assembly
4	KSC-466360-MB10	1	Machine Bushing, 10 Ga.
5	MF6H	2	Flat Washer, 3/4" High Strength
6	106-N1	1	HHCS, 3/4" x 14" Bolt, Gr. 5
7	KSC-466360-MB14	2	Machine Bushing, 14 Ga.
8	KSC-466360-CP	1	Cotter Pin, 1/4" x 2"
9	KSC-466360-GF	2	Drive Zerk
10	KSC-466300-HUB	1	N633 Hub Assembly w/Bearings
11	KSC-531020	1	Coulter Arm Assembly
12	SPR-1 (20" & 24")	1	Main Spring
13	S1244SL-SPC	2	Spring Cap Weldment
14	N6	1	Hex Nut, 3/4" High Strength
15	N6J	1	Hex Jam Nut, 3/4"
16	KSC-466300-SPL	1	N633 Spindle w/Hardware
17	KSC-466315-C	1	Collar
	20 PL COMBO		20" Smooth Blade (Not Shown)
	20 FL COMBO		20" Fluted Blade (Not Shown)
	20 FLC COMBO		20" Crucible Blade (Not Shown)
	20 NO COMBO		20" Notched Blade (Not Shown)

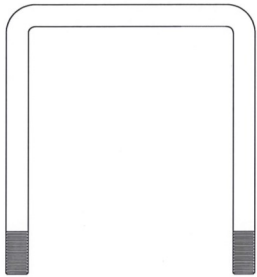
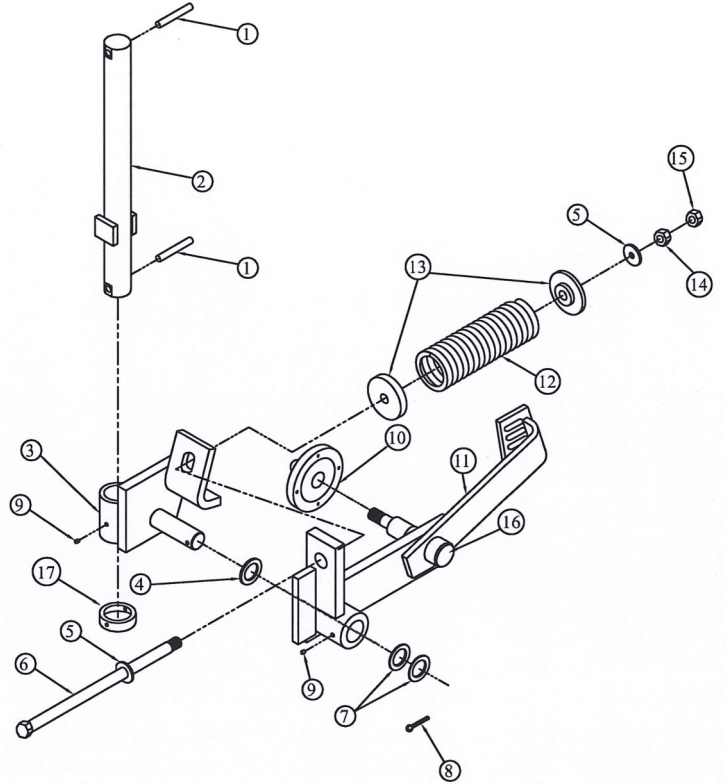

3/4" U-Bolt
for 7 x 7 Toolbar
Comes with nuts and
lockwashers

COULTER HUB

PARTS LIST			
No.	Part #	Qty.	Part Description
	KSC-466300-HUB		Comes Complete w/Items 1-8
1	KSC-LM67010	1	Inner Bearing Cup (Large Race)
2	KSC-LM11910	1	Outer Bearing Cup (Small Race)
3	KSC-LM67048	1	Inner Bearing Cone (Large Rollers/Cage)
4	KSC-LM11949	1	Outer Bearing Cone (Small Rollers/Cage)
5	KSC-909911	1	Hub Cap
6	KSC-906296	1	Seal
7	KSC-913572	4	Flange Head Bolt
8	KSC-G1641-B	1	1/4"-28 x 35/64" Grease Zerk
	KSC-466300-SPL		Comes Complete w/Items 9-11
9	KSC-913608	1	Spindle Washer
10	KSC-912953	1	Spindle Castle Nut
11	KSC-905936	1	Spindle Cotter Pin

Note:
HUB P/N KSC-466300-HUB comes complete with items 1-8

Note:
SPINDLE P/N KSC-466300-SPL comes complete with items 9-11

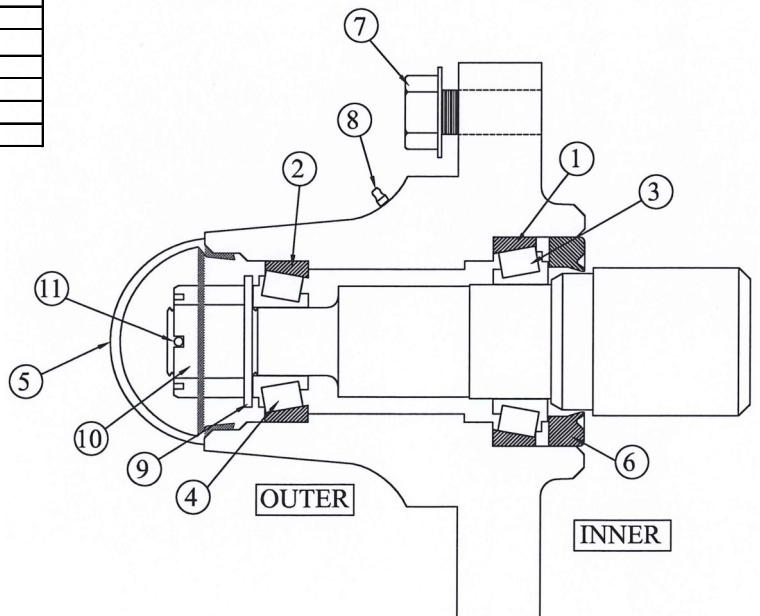

7 x 7 STANDARD COULTER MOUNT

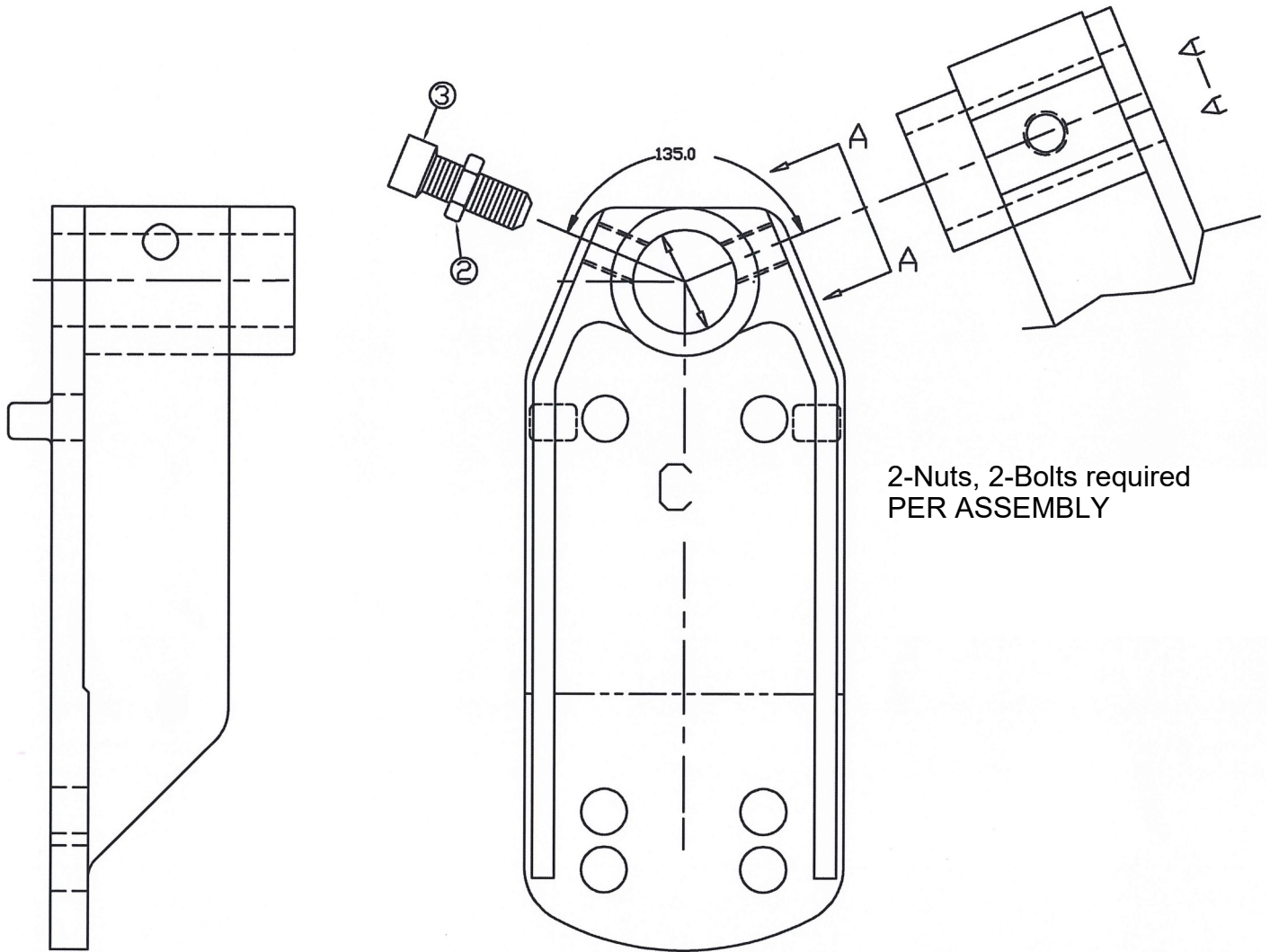

2-Nuts, 2-Bolts required
PER ASSEMBLY

PARTS LIST			
No.	Part #	Qty.	Part Description
1	KSC-466670C	1	Bar MTG Tube
2	N6J	2	Hex Jam Nut
3	106-B1	2	Set Screw, 3/4"-10 x 2" Square Head Cup Point
1	KSC-466571-4R	1	4" Right Hand Off-set Mount
1	KSC-466574-4L	1	4" Left Hand Off-set Mount

7 x 7 OFFSET COULTER MOUNT

PARTS LIST			
No.	Part #	Qty.	Part Description
1	KSC-466571-4MP	1	Coulter Mount Plate, 7", 4" Offset
2	KSC-466340-BMT	1	Bar MTG Tube, 2-3/8 x 3-5/8
3	KSC-466571-4GL	1	KSC-466571-4G Formed Offset Gusset
4	KSC-466571-4G1L	1	KSC-466571-4G1 Formed Offset Gusset
5	KSC-466340-4G2	1	Offset Coulter Mount Gusset
6	N6H	1	Hex Nut, 3/4"-10, Gr. 2
7	N6J	1	Hex Jam Nut
8	106-B1	1	Set Screw, 3/4"-10 x 2" Square Head Cup Point

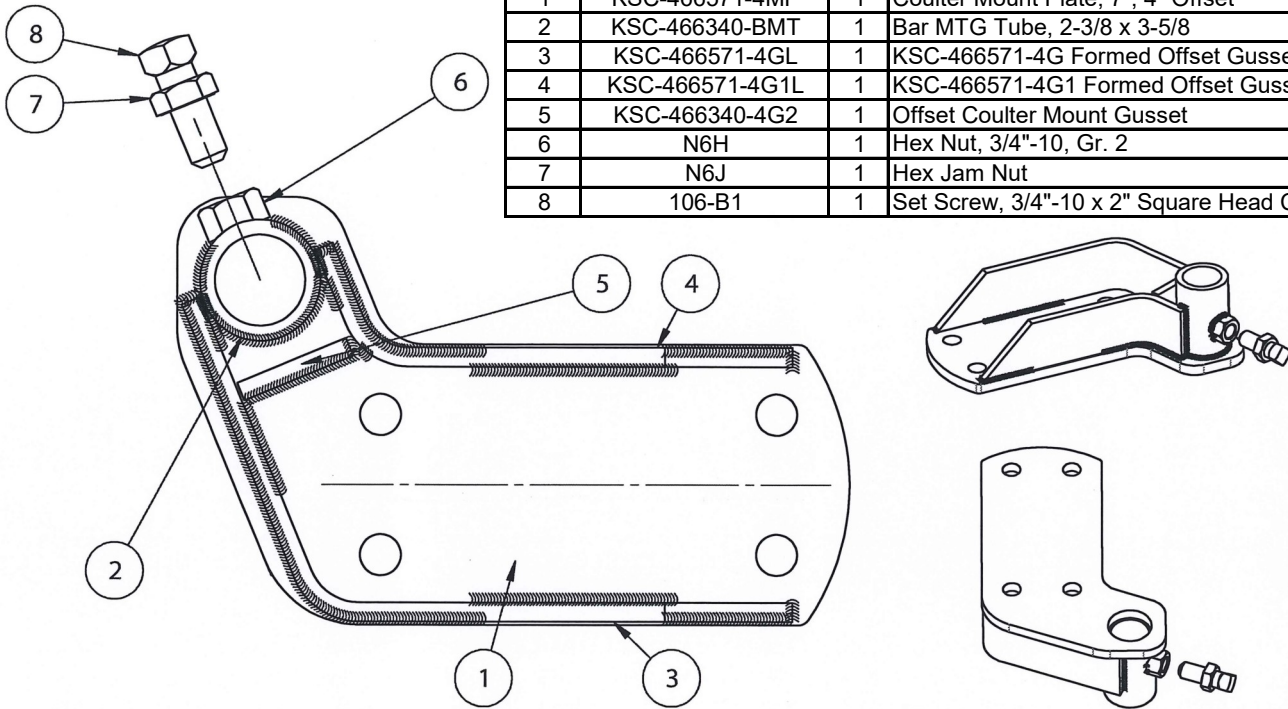

PARTS LIST			
No.	Part #	Qty.	Part Description
1	KSC-466571-4MP	1	Coulter Mount Plate, 7", 4" Offset
2	KSC-466340-BMT	1	Bar MTG Tube, 2-3/8 x 3-5/8
3	KSC-466571-4GR	1	KSC-466571-4G Formed Offset Gusset
4	KSC-466571-4G1R	1	KSC-466571-4G1 Formed Offset Gusset
5	KSC-466340-4G2	1	Offset Coulter Mount Gusset
6	N6H	1	Hex Nut, 3/4"-10, Gr. 2
7	N6J	1	Hex Jam Nut
8	106-B1	1	Set Screw, 3/4"-10 x 2" Square Head Cup Point

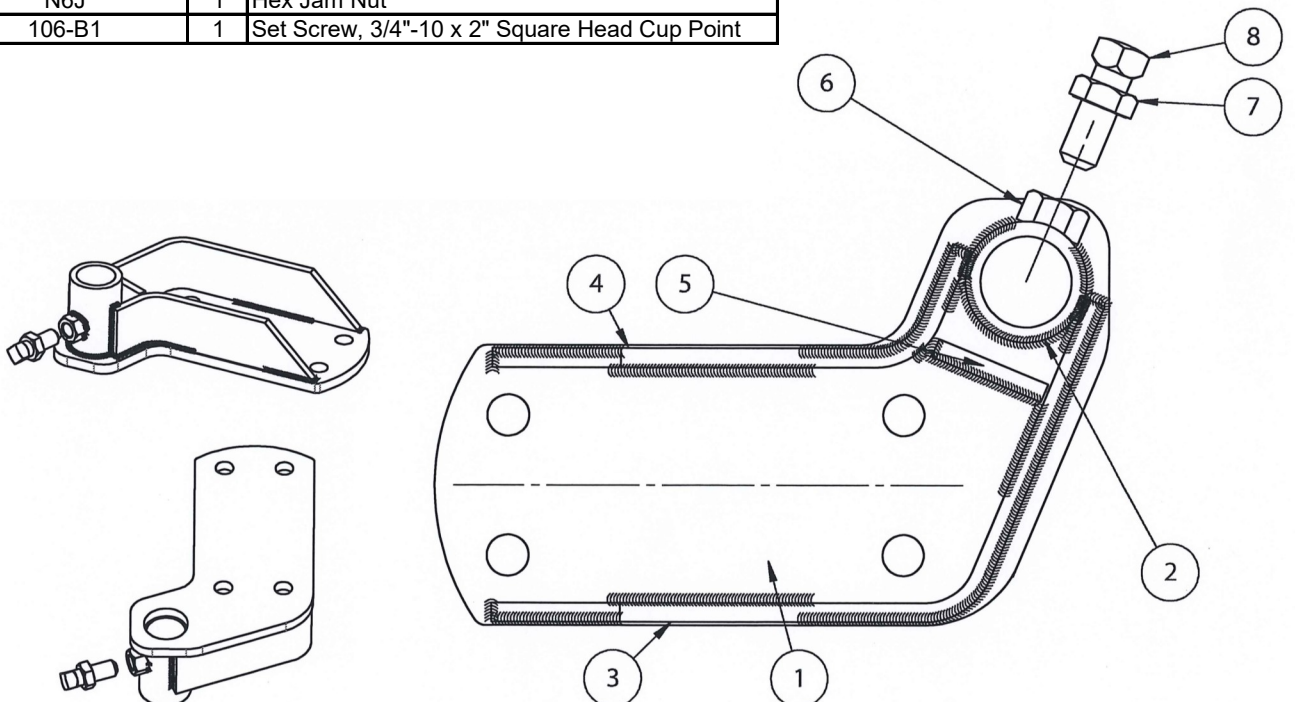

Technical Details

Operating Pressure (max): Inlet 3000 PSI (207 bar) Outlet: 3000 PSI (207 bar)
 Regulated Flow (max): 14 GPM (53 LPM) - Bypass Port Plugged (0 gpm Bypass)
 15 GPM (57 LPM) - Bypass Port Open (15 gpm Max Bypass)

Electrical:

Voltage: 12 VDC
 Frequency: 110 Hz
 Valve Type: Normally Closed Proportional Flow Control
 Threshold (Activation) Current: 350+/-100 mA
 Max. Control Current: 1600+/-200 mA
 Initial Current Draw: 2.7 amps
 Power: 32.8 watts
 Resistance: 4.5 ohms at 68 degree F (20 degree C)
 Storage Temperature: 32 to 140 degrees F (0 to 60 degrees C)
 Fluids: Mineral based or synthetic hydraulic fluid at viscosities of 7.4 to 420 cSt

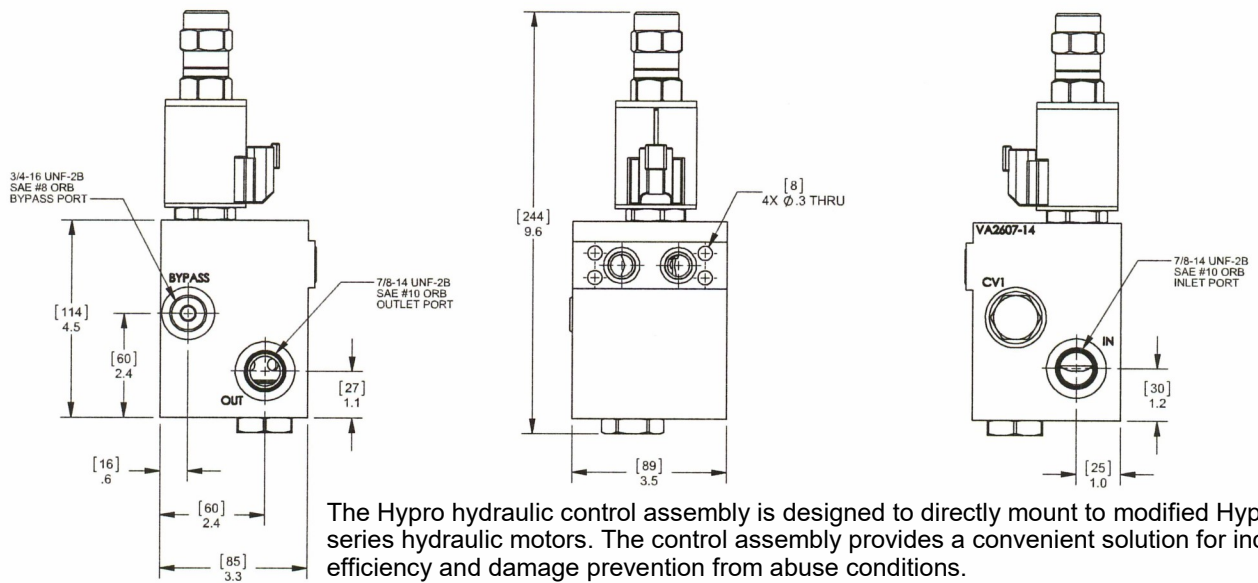
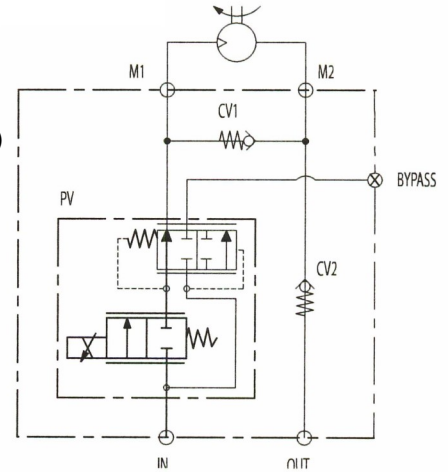

The Hypro hydraulic control assembly is designed to directly mount to modified Hypro HM series hydraulic motors. The control assembly provides a convenient solution for increased efficiency and damage prevention from abuse conditions.

Operation Instructions

The hydraulic control assembly is designed to work with a digital controller with PWM signal output. As the signal current increases, the hydraulic flow control valve opens.

To ensure proper hydraulic oil flow metering, follow the calibration procedure described by the manufacturer of the controller that is being used as each controller's procedure is different. In general, balancing reaction time and system stability are key to proper calibration.

The hydraulic flow control valve has a manual override option fitted from the factory. This feature can be used to open or close the valve in the event that the digital controller has an error or fails. To use this feature, remove the override cover on the top of the valve to reveal the red override toggle. The override is engaged by turning the toggle clockwise. One full turn is required to start opening the valve and full open is achieved with 6 full turns. To close the valve, turn the toggle counter clockwise 6 turns until a stop is reached.

Connections to the control assembly are SAE #10 (7/16-14 UNF-2B) O-ring boss ports. Ensure that the mating fitting has an O-ring free of any debris or damage before installation.

Match the high pressure line to the port labelled "IN" and the low pressure line back to tank to the port labelled "OUT".

The port labelled "BYPASS" is a SAE #8 (3/4-16 UNF-2B) port intended return excess oil flow back to the reservoir. This port comes plugged from the factory. When plugged, the hydraulic control assembly can be used with the hydraulic circuits that have a variable displacement pump. If the hydraulic circuit uses a fixed displacement pump, the plug must be removed and a line should be run from the bypass port to the reservoir. The maximum input flow is 30 GPM (114 LPM) for the bypass configuration.

No.	Part #	Description	Qty.	Included in 3430-0876 Service Kit
1	2500-0144C	Hydraulic Motor, HM1	1	
2	2210-0217	Bolt	4	X
3	0204-2500C5	Motor End Cover	1	X
4	3320-0079	Valve, Check-12	1	
5	3320-0078	Valve, Check-10	1	
6	3320-0080	Valve, Flow Control HM1	1	
6B	3320-0081	Valve, Flow Control HM4	1	
7	2525-0036	Solenoid	1	
8	2220-0129	Screw	4	X
9	2404-0443	Hydraulic Control Assy HM1	1	X
9B	2404-0452	Hydraulic Control Assy HM4	1	
-	2520-0212	Cable	1	

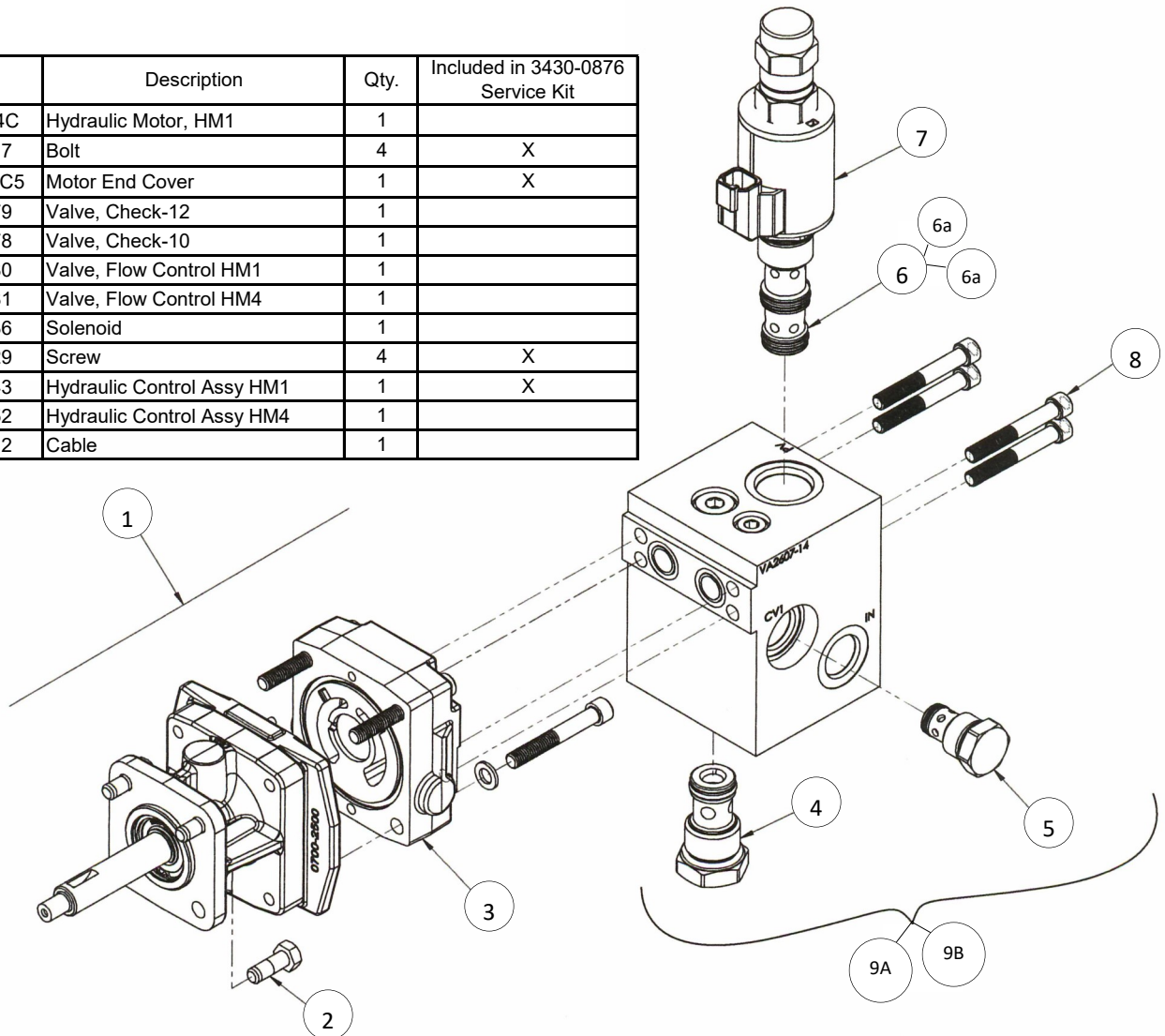

Service Instructions

The three valves used in the hydraulic control assembly are screw-in cartridge type valves and are replaceable. Each valve must be installed with the correct tightening torque to ensure proper operation. If the valve is tightened above the specified torque value, the valve internals may be damaged causing the valve to stick.

Before installing a new valve, inspect the valve to ensure all O-rings are seated in their appropriate grooves and have no damage, such as nicks or cuts.

Lubricate all O-rings with the oil being used in the hydraulic circuit. This will ensure the valve can slide into the cavity without dislodging or damaging the O-rings.

Screw in the new valve and tighten to the following specifications:

Valve	Cavity Label	Torque (Ft-Lbs) (Nm)
PV72-30 Flow Control	PV	33-37 (44.7-50.2)
Check Valve	CV1	24-26 (32.5-35.3)
Check Valve	CV2	33-37 (44.7-50.2)

Troubleshooting

Symptom	Corrective Action(s)
No flow from the pump	Engage the manual override on the flow control valve and send hydraulic flow to the motor. If no pump output is generated check the tractor hydraulic system for adequate supply flow and pressure or check the pump troubleshooting guide for pump evaluation.
No flow from the pump	Measure the resistance of the valve solenoid coil with an ohmmeter. The nominal resistance of the solenoid coil is 4.5 ohms. If the resistance rating is near zero or very high, the solenoid may be damaged.
Unstable pump performance	Review controller settings. Valve is normally closed, 110Hz PWM frequency. Decreasing brake point and/or increasing dead band tolerance settings incrementally may help improve stability.
Unable to get agitation flow	Review controller procedure for pump operation for manual control or methods for sending PWM signal to the valve while no flow is being detected by system flowmeters.

Limited Warranty on Hypro/Shurflo Agricultural Pumps & Accessories

Hypro/Shurflo (hereafter, "Hypro") agricultural products are warranted to be free of defects in material and workmanship under normal use for the time periods listed below, with proof of purchase.

- Pumps: one (1) year from the date of manufacture or one (1) year of use.
This limited warranty will not exceed two (2) years, in any event.
- Accessories: ninety (90) days of use.

This limited warranty will not apply to products that were improperly installed, misapplied, damaged, altered or incompatible with fluids or components not manufactured by Hypro. All warranty considerations were governed by Hypro's written return policy.

Hypro's obligation under this limited warranty policy is limited to the repair or replacement of the product. All returns will be tested per Hypro's factory criteria. Products found not defective (under the terms of this limited warranty) are subject to charges paid by the returnee for the testing and packaging of "tested good" non-warranty returns.

No credit or labor allowances will be given for products returned as defective. Warranty replacement will be shipped on a freight allowed basis. Hypro reserves the right to choose the method of transportation.

This limited warranty is in lieu of all other warranties, expressed or implied and no other person is authorized to give any other warranty or assume obligation or liability on Hypro's behalf. Hypro shall not be liable for any labor, damage or other expense, nor shall Hypro be liable for any indirect, incidental or consequential damages of any kind incurred by the reason of the use or sale of any defective product. This limited warranty covers agricultural products distributed within the United States of America. Other world market areas should consult with the actual distributor for any deviation from this document.

9306C-HM1C-BU-002 Pump

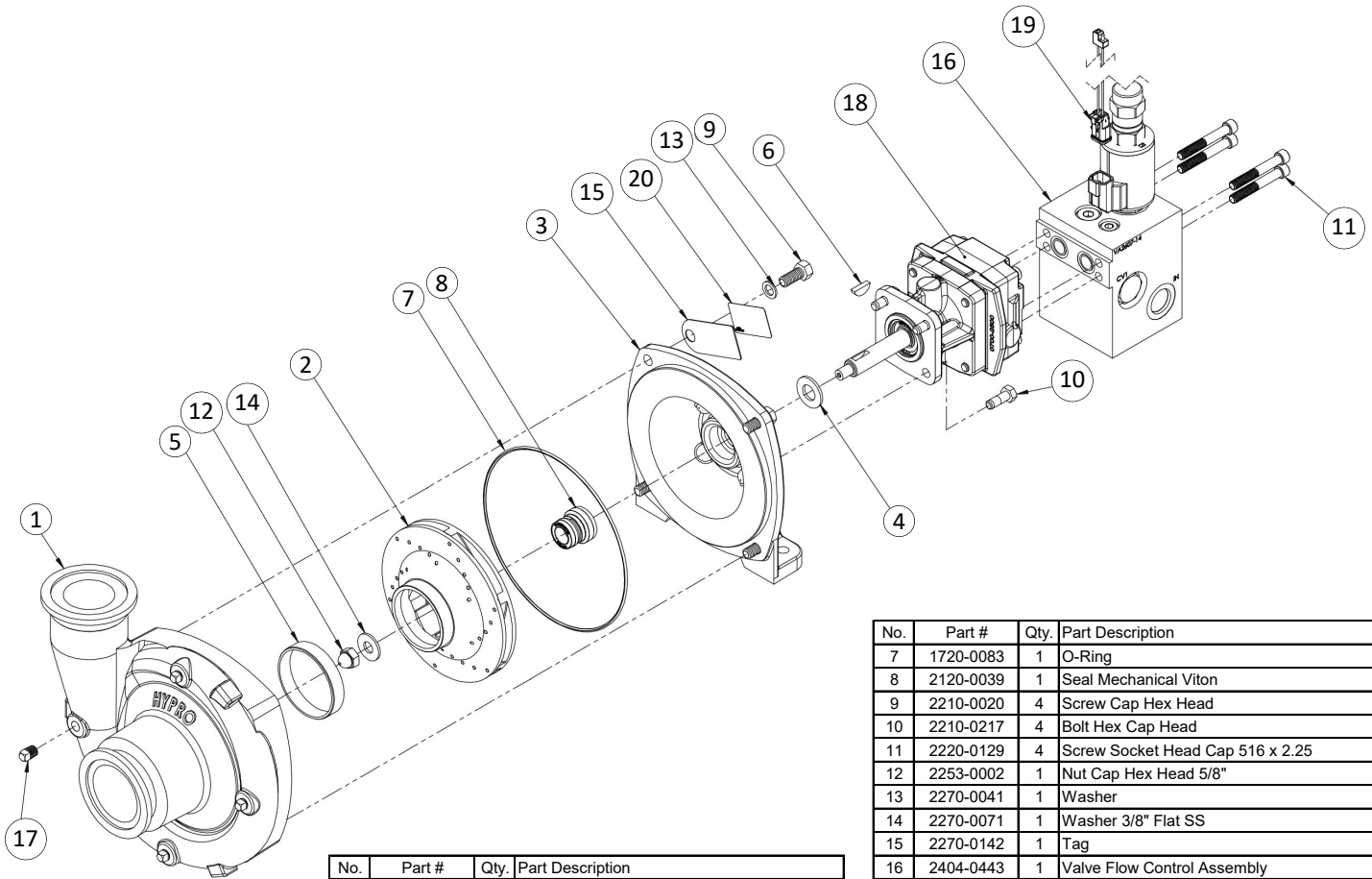

No.	Part #	Qty.	Part Description
1	0157-9200CM	1	Housing, 220x220 UF CI BK Machined
2	0401-9200P2	1	Impeller (CW Rotation)
3	0750-9300C2	1	Mounting Flange
4	1410-0056	1	Slinger Gasket, Shaft
5	1410-0096	1	Wear Ring
6	1610-0012	1	Woodruff Key

No.	Part #	Qty.	Part Description
7	1720-0083	1	O-Ring
8	2120-0039	1	Seal Mechanical Viton
9	2210-0020	4	Screw Cap Hex Head
10	2210-0217	4	Bolt Hex Cap Head
11	2220-0129	4	Screw Socket Head Cap 516 x 2.25
12	2253-0002	1	Nut Cap Hex Head 5/8"
13	2270-0041	1	Washer
14	2270-0071	1	Washer 3/8" Flat SS
15	2270-0142	1	Tag
16	2404-0443	1	Valve Flow Control Assembly
17	2406-0007	4	Pipe Plug
18	2500-0144R	1	Motor Hyd HM1C
19	2520-0212	1	Cable Hyd Valve
20	6031-0548	1	Label Blank
21	L-1546	1	OIPM 9306
22	L1575	1	OIPM Hydraulic Control

Ag Spray Warranty Info

LIMITED WARRANTY FOR NEW AG SPRAY EQUIPMENT

WHO MAY USE THIS LIMITED WARRANTY. This limited warranty (the "Limited Warranty") is provided by Fimco, Inc. ("Ag Spray Equipment") to the original purchaser ("you") of the Equipment (as defined below) from Ag Spray Equipment or one of Ag Spray Equipment's authorized dealers. This Limited Warranty does not apply to any subsequent owner or other transferee of the Equipment. THIS LIMITED WARRANTY GIVES YOU SPECIFIC LEGAL RIGHTS, AND YOU MAY ALSO HAVE OTHER RIGHTS WHICH VARY FROM STATE TO STATE.

WHAT THIS LIMITED WARRANTY COVERS AND FOR HOW LONG. Ag Spray Equipment warrants that any new Equipment will be free from defects in material and workmanship for a period of **one (1) year** (homeowner), **90 days** (commercial user), after delivery of the Equipment to you (the "Warranty Period"). The Warranty Period is not extended if Ag Spray Equipment repairs or replaces the Equipment.

WHAT IS NOT COVERED BY THIS LIMITED WARRANTY. This Limited Warranty does not apply to: (1) used Equipment; (2) any Equipment that has been altered, changed, repaired or treated since its delivery to you, other than by Ag Spray Equipment or its authorized dealers; (3) damage or depreciation due to normal wear and tear; (4) defects or damage due to failure to follow Ag Spray Equipment's operator's manual, specifications or other written instructions, or improper storage, operation, maintenance, application or installation of parts; (5) defects or damage due to misuse, accident or neglect, "acts of God" or other events beyond Ag Spray Equipment's reasonable control; (6) accessories, attachments, tools or parts that were not manufactured by Ag Spray Equipment, whether or not sold or operated with the Equipment; or (7) rubber parts, such as tires, hoses and grommets.

HOW TO OBTAIN WARRANTY SERVICE. To obtain warranty service under this Limited Warranty, you must (1) provide written notice to Ag Spray Equipment of the defect during the Warranty Period and within **thirty (30) days** after the defect becomes apparent or the repair becomes necessary, at the following address: Ag Spray Equipment, 1000 Fimco Lane, North Sioux City, SD 57049; and (2) make the Equipment available to Ag Spray Equipment or an authorized dealer within a reasonable period of time. For more information about this Limited Warranty, please call: **800-274-1025**

WHAT REMEDIES ARE AVAILABLE UNDER THIS LIMITED WARRANTY. If the conditions set forth above are fulfilled and the Equipment or any part thereof is found to be defective, Ag Spray Equipment shall, at its own cost, and at its option, either repair or replace the defective Equipment or part. Ag Spray Equipment will pay for shipping and handling fees to return the repaired or replacement Equipment or part to you.

LIMITATION OF IMPLIED WARRANTIES AND OTHER REMEDIES. THE REMEDIES DESCRIBED ABOVE ARE YOUR SOLE AND EXCLUSIVE REMEDIES, AND AG SPRAY EQUIPMENT'S SOLE LIABILITY, FOR ANY BREACH OF THIS LIMITED WARRANTY. TO THE EXTENT APPLICABLE, ANY IMPLIED WARRANTIES, INCLUDING, WITHOUT LIMITATION, THE IMPLIED WARRANTIES OF MERCHANTABILITY AND FITNESS FOR A PARTICULAR PURPOSE, SHALL BE LIMITED IN DURATION TO THE WARRANTY PERIOD, AND THE REMEDIES AVAILABLE FOR BREACH THEREOF SHALL BE LIMITED TO THE REMEDIES AVAILABLE UNDER THIS EXPRESS LIMITED WARRANTY. SOME STATES DO NOT ALLOW LIMITATIONS ON HOW LONG AN IMPLIED WARRANTY LASTS, SO THE ABOVE LIMITATION MAY NOT APPLY TO YOU. IN NO EVENT SHALL AG SPRAY EQUIPMENT'S LIABILITY UNDER THIS LIMITED WARRANTY EXCEED THE ACTUAL AMOUNT PAID BY YOU FOR THE DEFECTIVE EQUIPMENT, NOR SHALL AG SPRAY EQUIPMENT BE LIABLE, UNDER ANY CIRCUMSTANCES, FOR ANY CONSEQUENTIAL, INCIDENTAL, SPECIAL OR PUNITIVE DAMAGES OR LOSSES, WHETHER DIRECT OR INDIRECT. SOME STATES DO NOT ALLOW THE EXCLUSION OR LIMITATION OF INCIDENTAL OR CONSEQUENTIAL DAMAGES, SO THE ABOVE LIMITATION OR EXCLUSION MAY NOT APPLY TO YOU.

LA5000 LIQUID APPLICATOR



09/18



BAKERSFIELD, CA
4618 SACO RD, 93308
661.391.9081
Toll Free: 877.724.2236
F: 661.391.9085
BAKERSFIELD@AGSPRAY.COM

COLUMBUS, NE
5834 23rd ST, 68601
402.564.4544
Toll Free: 800.274.1025
F: 402.564.0549
COLUMBUS@AGSPRAY.COM

DOTHAN, AL
2401 FORRESTER RD, 36301
334.673.0580
Toll Free: 800.227.4098
F: 334.673.1974
DOTHAN@AGSPRAY.COM

FARGO, ND
4350 48th AVE N, 58102
701.280.2862
Toll Free: 800.373.4084
F: 701.293.0961
FARGO@AGSPRAY.COM

HOPKINSVILLE, KY
3303 PEMBROKE RD, 42240
270.886.0296
Toll Free: 800.637.7172
F: 270.885.7392
HOPKINSVILLE@AGSPRAY.COM

MANKATO, MN
907 SOUTHBEND AVE, 56001
507.377.6295
Toll Free: 800.722.9376
F: 507.388.4668
MANKATO@AGSPRAY.COM

NEWTON, KS
7000 SCHABEN CT, 67114
316.283.4444
Toll Free: 800.394.7662
F: 316.293.4646
NEWTON@AGSPRAY.COM

PASCO, WA
3035 TRAVEL PLAZA WAY, 99301
509.488.6631
Toll Free: 800.634.2026
F: 509.488.2927
OTHELLO@AGSPRAY.COM

TEMPE, AZ
8464 KYRENE RD, 85284
480.705.8047
Toll Free: 877.705-8047
F: 480.705.8048
TEMPE@AGSPRAY.COM