

FR310V Parts List

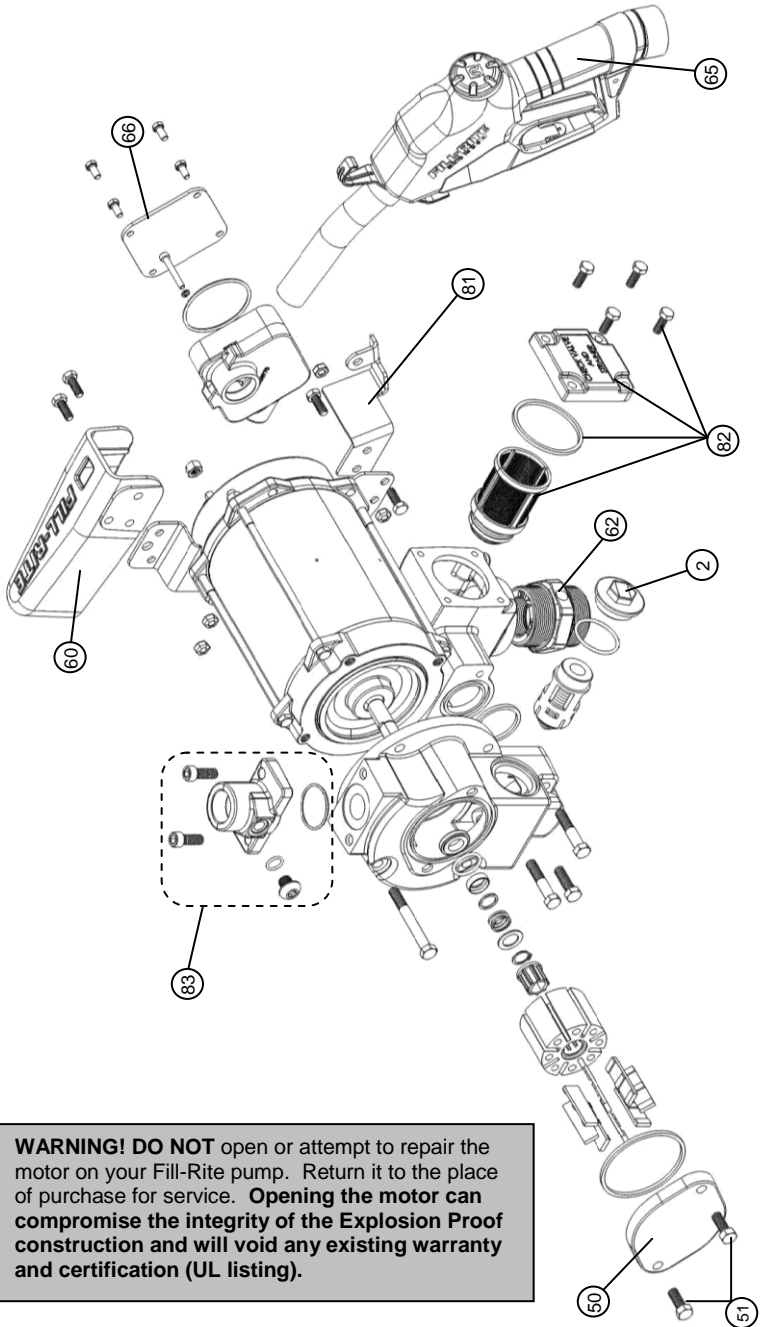

WARNING! DO NOT open or attempt to repair the motor on your Fill-Rite pump. Return it to the place of purchase for service. **Opening the motor can compromise the integrity of the Explosion Proof construction and will void any existing warranty and certification (UL listing).**

FR300V Parts List

No	Part / Kit #	Description	Kit #	Qty
2	KIT300BV	Bypass Kit (includes cap, valve, and gasket)		1
3	Repair Kit 300KTF7794**	Gasket, Lathe Cut, Nitrile	Seal Kit KIT700SL	1
5		Pump Rotor, Machined		1
6		Vane, Carbon Epoxy Impregnated		8
11		O-Ring, Flourocarbon, -131		1
15		O-Ring, Flourocarbon,-120		1
16		Inner Seal, Carbon		1
17		O-Ring, Flourocarbon,-114		1
19		Seal Ring		1
21		Spring, Seal		1
22		Washer, Shaft		1
23		Retaining Ring, External 5/8		1
24		Rotor Insert		1
28		Gasket, Lathe Cut, Nitrile		1
30		Bypass Assembly		1
33		Gasket, Lathe Cut, Nitrile		1
50	Rotor Cover	1		
51	Attaching Screws	2		
60	KIT120NB	Standard Nozzle Boot, Cast		1
62	KIT700BG	Machined Tank Adapter AST 2 x 1¼		1
65	N100DAU13	1" Automatic Nozzle (truck diesel spout)		1
66	KIT300JC	Junction Box Cover (includes hardware and gasket)		1
80	KIT300MA	Meter Flange (includes hardware and gaskets)		1
81	KIT300NR	Nozzle Retainer (includes hardware)		1
82	KIT300SG	Check Valve / Strainer Cover		1
N/S	KIT300BD	Bio-Diesel Conversion Kit		1
N/S	KIT700AS	Anti-Siphon Kit	See page 7	1
83	KIT300OT	Straight Outlet Flange (includes hardware and gaskets)		1
N/S	KIT300SW	Switch Lever (includes attaching nut)		1

*Rotor cover (50) and screws (51) are included in 300KTF7794

**Use BD300KTH0712 for model BD310V

N/S = Not Shown in any diagrams

Repair Kit 300KTF7794 and Seal Kit KIT700SL Detail

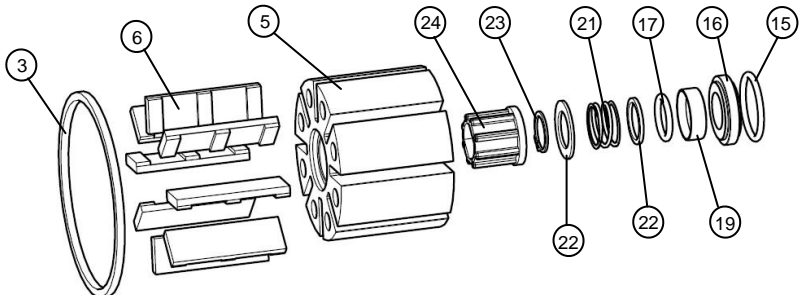

FR319V Parts List

The FR319V configuration adds a 900DB or 900DP series digital meter, inlet meter flange, outlet meter flange, the associated attaching hardware, and gaskets. This package is available in pulsing or non-pulsing configuration.

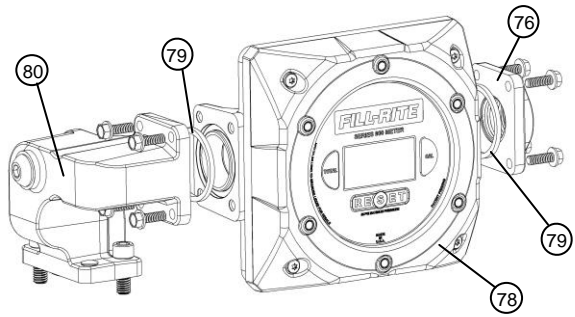

No.	FR319VB (Non-pulsing Meter pkg.)	Description	FR319VBP (Pulsing Meter pkg.)	Qty
78	900DB Digital Meter (no pulser) FR319VB	900DB Meter (only)	900DP Meter (w/integral pulser) FR319VBP	1
76		Meter Flange		1
79		Meter Gasket		2
80		1" Meter Fitting		1
78	FR900DB	900DP Meter (only)		1
N/S		Intrinsic Safety Barrier*	KIT900DPBA	1

*For use with 900DP pulsing meter only

FR311V Parts List

The FR311V configuration adds a 900 Series mechanical meter, inlet meter flange, outlet meter flange, the associated attaching hardware, and gaskets. This package is available in gallon or liter register.

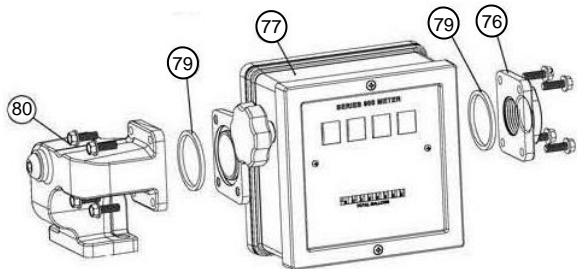

No.	Gallon Kit Number	Description	Liter Kit Number	Qty
77	901	900 Meter (only) (Gallons)		1
76	900 Meter (Gallon) Kit # 901MK300V	Meter Flange	900 Meter (Liter) Kit # 901LMK300V	1
79		Meter Gasket		2
80		1" Meter Fitting		1
77		900 Meter (only) (Liters)	901L	1

Fluid Compatibility

Diesel Fuel Gasoline Kerosene Mineral Spirits Stoddard Solvents
 Heptane Bio-Diesel (B20 max.) *Bio-Diesel (B21 – B100)



IMPORTANT! If in doubt about compatibility of a specific fluid, contact supplier of fluid to check for any adverse reactions to the following wetted materials: **cast iron; steel; zinc plated steel; 300 series stainless steel; bronze; carbon; ceramic; polyester; fiber; fluorocarbon; buna; 400 series stainless steel; aluminum.**

*Model BD310V **ONLY**

Owners Installation, Operation, and Safety Manual



Series **300V**

Fuel Transfer Pump

Series 300V – 115 and 230 VOLT AC

Table of Contents

Table of Contents.....	2
Thank You!.....	2
About This Manual	2
Safety Information.....	3
Installation.....	3
Anti-Siphon Device	7
Nozzle Boot Installation	7
Electrical Wiring	8
Wiring Procedure	8
Operating Instructions.....	9
Pad Locking	9
Trouble Shooting.....	9
Accessories.....	11
Safety Testing Approvals	11
Replacement Parts Information.....	11
Fluid Compatibility.....	14
Technical Information / Specifications.....	15
300VE Model Information.....	16

Thank You!

Thank you for your purchase of the Fill-Rite series 300V pump! Your Fill-Rite product comes with over 50 years of pump manufacturing experience behind it, providing you the value that comes with superior performance, user friendly design, long service life, and solid, simple engineering. Experience that gives you peace of mind.

Excellence at Work. Excellence in Life.

About This Manual

From initial concept and design through its final production, your Fill-Rite pump is built to give you years of trouble free use. To insure it provides that service, **it is critical that you read this entire manual prior to attempting to install or operate your new pump.** Become familiar with the terms and diagrams, and pay close attention to the highlighted areas with the following labels:



WARNING! Emphasizes an area in which personal injury or even death could result from failure to follow instructions properly. Mechanical damage may also occur.



IMPORTANT! These boxes contain information that illustrates a point that may save time or may be key to proper operation, or clarifies a step.



CAUTION! Failure to observe a “Caution” can cause damage to the equipment.

At Tuthill, your satisfaction with our products is paramount to us. If you have questions or need assistance with your product, please contact us at 1-800-634-2695 (M-F 8 AM–5 PM ET).

Safety Information



WARNING! Electrical wiring should be performed **ONLY** by a licensed electrician in compliance with local, state, and national electrical code NEC/ANSI/NFPA 70, NFPA30, and NFPA 30A, as appropriate to the intended use of the pump. Threaded rigid conduit, sealed fittings, and conductor seal should be used. The pump must be properly grounded. Improper installation or use of this pump can result in serious bodily injury, or death!



WARNING! To insure safe and proper operation of your equipment, it is critical to read and adhere to all of the following safety warnings and precautions. Improper installation or use of this product can cause serious bodily injury or death!

1. **NEVER** smoke near the pump, or use the pump near open flames when pumping a flammable liquid! Fire can result!
2. A Fill-Rite Filter should be used on the pump outlet to insure no foreign material is transferred to the fuel tank.
3. Threaded pipe joints and connections should be sealed with the appropriate sealant or sealant tape to minimize the possibility of leaks.
4. Storage tanks should be securely anchored to prevent shifting or tipping when full or empty.
5. To minimize static electricity build up, use only static wire conductive hose when pumping flammable fluids, and keep the fill nozzle in contact with the container being filled during the filling process.
6. The pump motor is equipped with thermal overload protection; if overheated, the motor will shut off to prevent damage to the windings. If this happens, **TURN THE PUMP OFF!** When the motor cools, it will restart without warning if the power is on.



WARNING! This product shall not be used to transfer fluids into any type of aircraft.



WARNING! This product is not suited for use with fluids intended for human consumption or fluids containing water.

Installation

The Fill-Rite series 300V pump is designed to offer several different mounting configurations. It can be mounted on a skid tank using the tank adapter supplied with the pump (see attached diagrams), direct mounted to the top of an underground tank, or mounted on a concrete island using an optional pedestal adapter (available through your Fill-Rite distributor). Regardless of mounting style, all tanks must be properly vented, and skid tank installations should employ an anti-siphon device.

The series 300V pump has a built in check valve with pressure relief to reduce unsafe excess pressure from thermal expansion of the fluid. It also features an integral bypass valve to help minimize wear when the pump is operating with the nozzle closed.



WARNING! In “Skid Tank” applications, be sure the tank is properly secured so it cannot shift or move when the tank is empty or full.



WARNING! Installations must comply with all local, state, and national fire codes, as appropriate to the intended use of the pump.



CAUTION! A pressure retaining fill cap can be used to reduce fuel loss through evaporation, but note that it may reduce the flow rate.



CAUTION! Do not use additional check valves or foot valves unless they have a proper pressure relief valve built into them. Note that additional check valves will reduce rate of flow.

Typical Skid Tank Installation



WARNING! Threaded pipe joints and connections should be sealed with the appropriate sealant or sealant tape to minimize the possibility of leaks.

Materials:

- 1-1/4" pipe cut to a length that will terminate at least 3" from the bottom of the tank when installed into the tank adapter with the tank adapter installed into the tank flange (see **SKID TANK INSTALLATION** diagram).
- Threaded pipe joint sealant appropriate for application.

Installation Procedure:

- 1) Thread the 1-1/4" pipe into the tank adapter. Seal threads liquid tight with appropriate thread sealant.
- 2) Install the tank adapter into the tank flange; seal threads liquid tight with appropriate thread sealant.
- 3) Mount the pump on the adapter; seal threads liquid tight with appropriate thread sealant.
- 4) Fill-Rite recommends installation of our Anti-Siphon Device (see page 7 for detailed information).

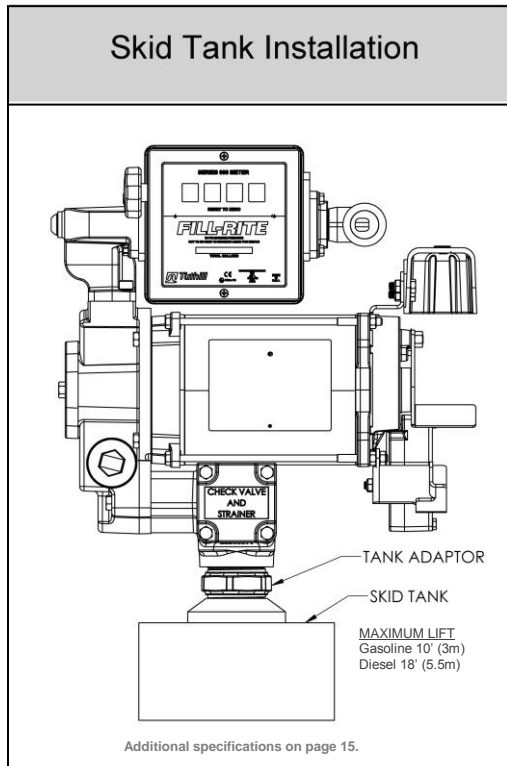

Typical Direct Mount Installation (to underground tank)



WARNING! Threaded pipe joints and connections should be sealed with the appropriate sealant or sealant tape to minimize the possibility of leaks.

Materials:

- 2" pipe cut to length and threaded at both ends that will extend approximately 31" above the ground when installed in the tank flange.
- 1-1/4" pipe cut to a length that will terminate at least 3" from the bottom of the tank when installed into the tank adapter with the tank adapter installed into the 2" pipe coupler (see **DIRECT MOUNTING INSTALLATION** diagram).
- Threaded pipe joint sealant appropriate for application.

Installation Procedure:

- 1) Install the 2" pipe in the tank flange; seal threads liquid tight with appropriate sealant.
- 2) Screw a 2" standard pipe coupling onto the top of the pipe; seal threads liquid tight with appropriate sealant.
- 3) Install the 1-1/4" pipe into the tank adapter. Seal threads liquid tight with appropriate sealant.
- 4) Install the tank adapter into the 2" coupling; seal threads liquid tight with appropriate sealant.
- 5) Mount pump on tank adapter; seal threads liquid tight with appropriate sealant.

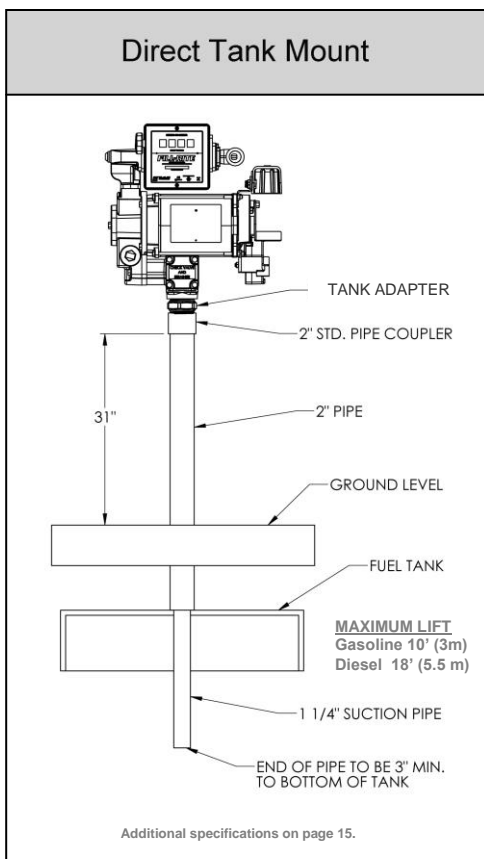

Typical “Pedestal / Island” Installation



WARNING! Threaded pipe joints and connections should be sealed with the appropriate sealant or sealant tape to minimize the possibility of leaks.

Materials:

- 1-1/4” threaded suction pipe, cut to extend 32-1/2” above the island.
- FRPA125 Pedestal Kit (includes Pedestal Pipe, Base, & Coupler).
- Threaded pipe joint sealant appropriate for application.

Installation Procedure:

- 1) Remove the coupler from the pedestal pipe by loosening the set screws.
- 2) Slip the pedestal pipe / pump base assembly over the 1-1/4” suction pipe.
- 3) Loosen the screws in the pedestal base to allow the pedestal pipe to slide down exposing the end of the suction pipe.
- 4) Screw the coupler onto the suction pipe; seal threads liquid tight with appropriate thread sealant.
- 5) Slide the pedestal pipe into the coupler and tighten the set screws.
- 6) Tighten the screws in the pedestal base.
- 7) Mount the pump on the coupler and seal threads liquid tight with appropriate thread sealant.

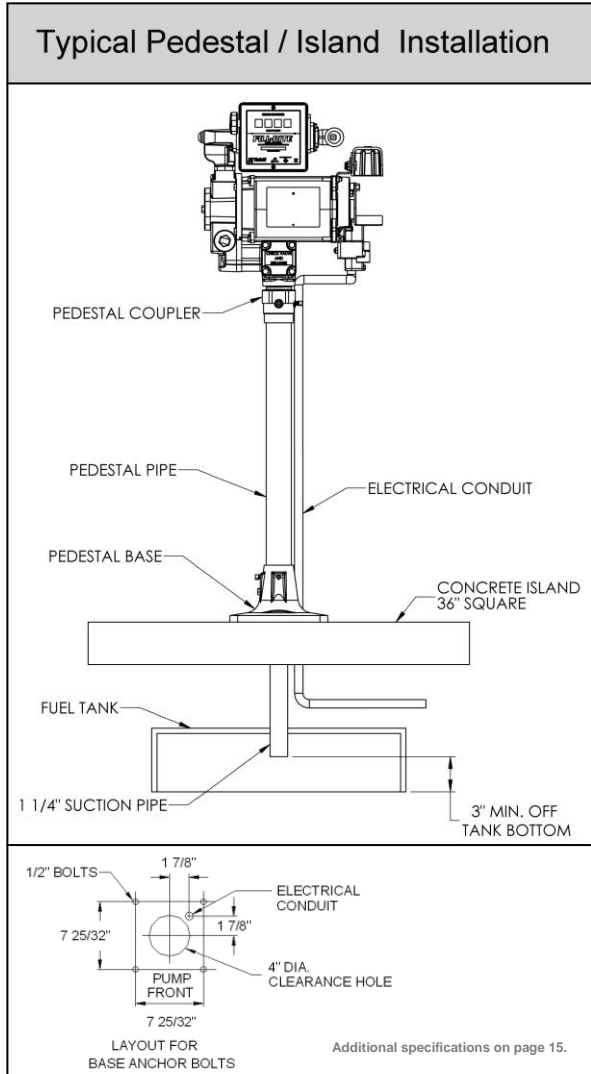

Anti-Siphon Device

Your series 300V pump comes from the factory ready to install an anti-siphon tube back to the tank. An anti-siphon device (a.k.a. vacuum breaker) is important because it will break a liquid siphon if there is an open nozzle or a leaking hose below the fluid level in the tank when the pump is turned off. Fill-Rite recommends anti-siphon kit #KIT700AS be installed from the pump outlet back to the vapor space in the tank.

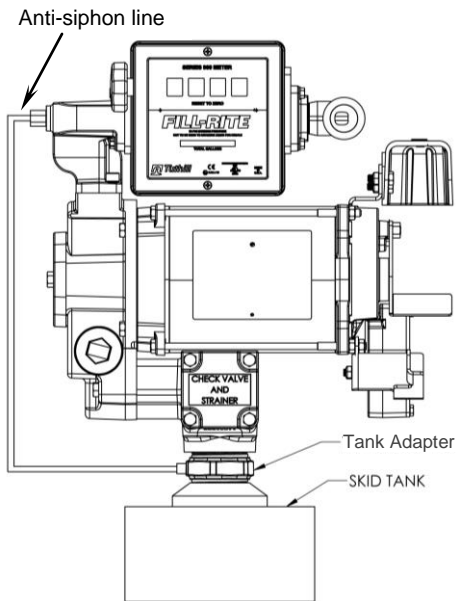

This illustration shows where to install the tube so that it terminates in the vapor space at the top of the tank. The tube must terminate in the vapor space; if it terminates below the fluid level in the tank, it will not prevent siphoning. It is very important there are no liquid traps in the tubing; it must have a continuous slope from the pump down to the tank, and can be connected into any opening in the top of the tank if the tank adapter is not used. Use reducer bushings as required for proper fit and seal. We recommend using the anti-siphon tank adapter with a 1/4 NPT opening in the side. This opening terminates in the vapor space of the tank. Make liquid-tight connections using the appropriate sealant from the adapter to the anti-siphon outlet using a minimum of 1/4 metal tubing that is compatible with whatever liquid is being pumped. If the anti-siphon tank adapter is being used and the 1/4 NPT opening is not used

for the tubing, leave the factory installed plug in place.

Fill-Rite offers **Anti-Siphon kit # KIT700AS** (available through your Fill-Rite distributor). This kit contains the necessary fittings and tubing to complete the installation as pictured in this section. **NOTE: This kit is required ONLY for tank top installations.**



WARNING! Threaded pipe joints and connections should be sealed with the appropriate sealant or sealant tape to minimize the possibility of leaks.

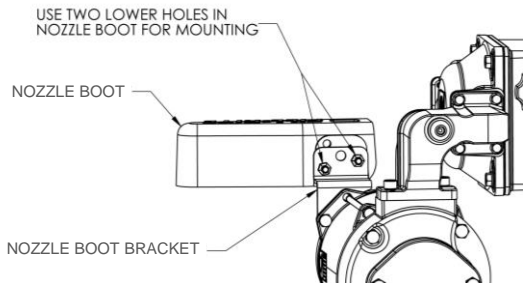

Nozzle Boot Installation

The nozzle boot is installed using the lower two screw holes on the side of the boot. Use supplied attaching hardware to install the nozzle boot.

When the nozzle is mounted correctly it will be in a horizontal position.

Electrical Wiring



WARNING! Electrical wiring should be performed **ONLY** by a licensed electrician in compliance with local, state, and national electrical code NEC/ANSI/NFPA 70, NFPA30, and NFPA 30A, as appropriate to the intended use of the pump. Threaded rigid conduit, sealed fittings, and conductor seal should be used. The pump must be properly grounded. Improper installation or use of this pump can result in serious bodily injury, or death!



CAUTION! All pumps should be operated at the Rated Nameplate Voltage. Power should be supplied to the pump from a dedicated 30 amp circuit breaker. No other equipment should be powered by this circuit. Wiring must be of sufficient size to carry the correct current for the pump. Voltage drop will vary with distance to pump and size of wire; refer to the National Electrical Code (NEC), or local codes, for Voltage Drop Compensation to be sure you are using the correct size wire for your application.

Wiring Procedure



WARNING! The “AUX.” wire **IS A LIVE WIRE** when the switch is on! The “AUX” lead wire is insulated and enclosed when shipped. **DO NOT** connect this wire without first verifying the “ON” line voltage of the wire for compatibility with the equipment to be installed. Maximum amperage on this wire is 1 amp. The “AUX” wire must be insulated and enclosed in the junction box if not used.

- 1) Remove the junction box cover and straighten the wires to make sure the stripped wire ends are accessible outside the junction box.
- 2) Connect the pump wires to the power supply lines according to the diagram. Be certain to properly insulate the connections with the appropriate wire nuts or other connectors. Note that the ground wire **MUST** be connected.
- 3) Fold the wires back into the junction box and replace the cover, making sure the cover gasket is in place.

Use the Voltage Selector Switch on the end of the pump to select the input voltage for the pump. **NOTE:** The pump comes from the factory pre-set to 115 VAC position (see diagram top of page 9).



IMPORTANT! Be certain the gasket for the cover is in place, and the screws draw the cover down tight over the junction box. There must be no gap between the junction box and its cover.

115 VOLT WIRE DIAGRAM **AUX LEAD RATED 1.0 AMP**

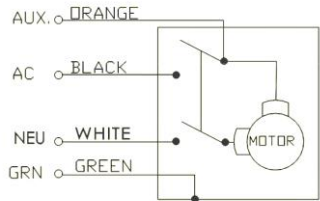

230 VOLT WIRE DIAGRAM **AUX LEAD RATED 1.0 AMP**

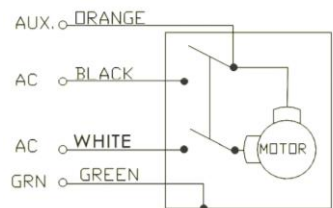

Operating Instructions

- 1) Reset Meter to "0" (if applicable).
- 2) Remove dispensing nozzle from nozzle boot.
- 3) Move the switch lever to the "ON" position to power the pump.
- 4) Insert the dispensing nozzle into the container to be filled.
- 5) Operate the nozzle to dispense fluid; release nozzle when the desired amount of fluid has been dispensed.
- 6) Move switch lever to the "OFF" position to stop the pump.
- 7) Remove the dispensing nozzle from the container and store it in the nozzle boot.

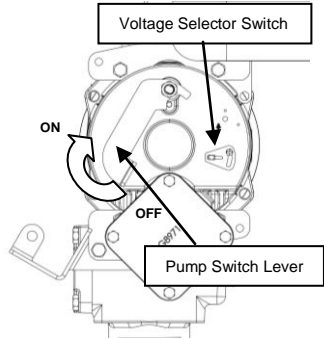

CAUTION! Always keep the nozzle in contact with the container being filled **during the filling process** to minimize the possibility of static electricity build up.

Pad Locking

Your Fill-Rite pump nozzle can be pad locked for added security. With the pump turned off, and the nozzle in the stored position, a pad lock can be inserted through the nozzle rest and nozzle handle opening. This configuration prevents the nozzle from being removed from the nozzle cover.

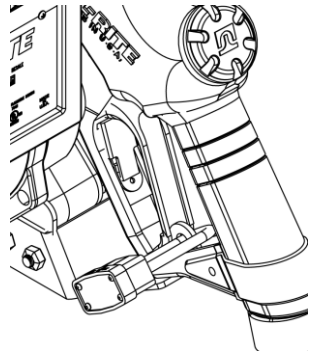

Trouble Shooting

The following Trouble Shooting guide is provided to offer basic diagnostic assistance in the event you encounter abnormal service from your Tuthill product.



WARNING! DO NOT open or attempt to repair the motor on your Tuthill pump. Return it to the place of purchase for service. **Opening the motor case can compromise the integrity of the Explosion Proof construction and will void any existing warranty and certification (UL listing).**

If you have questions regarding installing, operating, or servicing your product, please feel free to contact our Customer Service Department at 1-800-634-2695 (M-F 8 AM–5 PM ET). You can also reach us on the World Wide Web at "www.tuthill.com".



WARNING! Be certain all power to the pump is turned off prior to performing any service or maintenance.

Trouble Shooting (cont'd)

Symptom	Cause	Cure
Pump won't prime.	1. Suction line problem.	Check for leaks in suction line
	2. Bypass valve open.	Remove and inspect valve; must move freely & be free of debris.
	3. Vanes sticking.	Check vanes and slots for nicks, burrs and wear.*
	4. Excessive rotor or vane wear.	Inspect rotor & vanes for excessive wear or damage; replace if necessary.*
	5. Outlet blocked.	Check pump outlet, hose, nozzle & filter for blockage.
	6. Vapor Lock	Reduce vertical and horizontal distance from pump to liquid; remove automatic nozzle.
Low capacity.	1. Excessive dirt in screen.	Remove and clean screen.
	2. Suction line problem.	Check suction line for leaks or restrictions; it may be too small, too long or not airtight.
	3. Bypass valve sticking.	Remove and inspect valve; must move freely & be free of debris.
	4. Vanes sticking.	Check vanes and slots for wear.*
	5. Excessive rotor or vane wear.	Inspect rotor & vanes for excessive wear or damage; replace if necessary.*
	6. Hose or nozzle damage.	Replace hose or nozzle.
	7. Plugged filter.	Replace filter.
	8. Low fluid level.	Fill tank.
Pump runs slowly.	1. Incorrect voltage.	Check incoming line voltage while pump is running.
	2. Vanes sticking.	Inspect vanes and slots for nicks, burrs and wear.*
	3. Wiring problem.	Check for loose connections.
	4. Motor problem.	Return to place of purchase.
Motor stalls.	1. Bypass valve sticking.	Remove and inspect valve; must move freely & be free of debris.
	2. Low voltage.	Check incoming line voltage while pump is running.
	3. Excessive rotor or vane wear.	Check rotor & vanes for excessive wear or damage.*
	4. Debris in pump cavity.	Clean debris from pump cavity.
Motor overheats (Thermal overload tripped) .	1. Pumping high viscosity fluids.	These fluids can only be pumped for short periods of time (less than 30 minutes duty cycle).
	2. Clogged screen.	Remove and clean screen.
	3. Restricted suction pipe.	Remove and clean pipe.
	4. Motor failure.	Return to place of purchase.
	5. Pump rotor lock-up.	Clean and check pump rotor and vanes.*
Motor Inoperative.	1.No power	Check incoming power.
	2. Switch failure.	Return to place of purchase.
	3. Motor failure.	Return to place of purchase.
	4. Thermal protector failure.	Return to place of purchase.
	5. Incorrect/loose wiring.	Check wiring.

Trouble Shooting (cont'd)

Symptom	Cause	Cure
Fluid leakage.	1. Bad o-ring gasket.	Check all o-ring gaskets.
	2. Dirty shaft seal.	Clean seal & seal cavity.
	3. Bad shaft seal.	Replace seal.
	4. Incompatible fluid.	Refer wetted parts list to fluid manufacturer (see page 14).
	5. Loose fasteners.	Tighten fasteners.
Pump hums but will not operate.	1. Dirt in pump cavity.	Clean out pump cavity.
	2. Motor failure.	Return to place of purchase.
	3. Broken rotor insert.	Remove all debris & replace insert.

Bold text indicates repairs that are not serviceable by the owner; pump must be returned to the point of purchase for repairs.

* Repairs marked with an asterisk (*) will require Repair Kit #300KTF7794. This kit includes a replacement rotor and new vanes, as well as a number of other important seals and components to complete the repair. Details of this kit are on page 13.

Accessories

A wide variety of accessories are available to help you maximize the performance of your Fill-Rite pump. Listed below are the applicable available accessories for your specific product.

Please contact your authorized Fill-Rite distributor to purchase the accessories you need.

Part Number	Description
F4010PM0	1" Filter Kit (Particulate 10 micron)
F4030M0	1" Filter Kit (Particulate 30 micron)
700ACCF7017	1" Filter Head
FRPA125	Island Pedestal Mount Kit
KIT700AS	Anti-Siphon Kit
FRH10012	1" Hose (12')
FRH10014	1" Hose (14')
FRHA10020	1" Arctic Duty Hose (20')
FRHMN100S	1" Nozzle Kit, Manual Leaded Spout
N100DAU13	1" Auto Shut Off Nozzle (Ultra High Flow Diesel)
N100DAU10	1" Auto Shut Off Nozzle (High Flow Diesel)
FRNA100DAU00	1" Auto Shut Off Nozzle (Arctic Duty - Diesel)
S100H315	1" Multi-Plane Swivel

Safety Testing Approvals

The **Fill-Rite** line of pumps have been safety tested for compliance to the standards set forth by UL Laboratories (NOTE : Motor only on BD310V bio-diesel model).



Replacement Parts Information

For repairs or routine maintenance, Fill-Rite offers the parts you need. The following parts diagram and list covers all applicable parts for your Fill-Rite product. These parts can be obtained through any authorized Fill-Rite dealer. Be sure to use only genuine Fill-Rite replacement parts for your service and maintenance needs. For a list of authorized dealers, please visit our web site at "www.fillrite.com".

Technical Information / Specifications

Design Features

- Inlet: Bung : 2" male NPT; Suction pipe- 1-1/4" female NPT.
- Outlet: 1" NPT, or 1" BSPT (BSPT on model FR310VEMN and FR311VELMN).
- Cast iron pump housing: iron (composite) rotor, and carbon (composite) vanes.
- Security: Pump equipped for padlocking (see page 9 for details).
- Thermal Overload Protection.
- Heavy Duty Switch.
- 30 Minute Duty Cycle.
- Explosion proof motor UL listed with sealed bearings that require no maintenance.
- Integral check valve with pressure relief on inlet side prevents pressure build up and improves vertical lift.
- Easy access strainer.
- Automatic bypass valve.
- 2" threaded base for tank openings.
- Constant Amp Draw (Service Factor of 1.0):
 - 115VAC 60Hz – 9.8 amps
 - 230VAC 60Hz – 4.9 amps

Overall Dimensions:

Model 310V: 17.12" wide X 15" high x 14.9" deep.

Model 311V: 17.12" wide X 19.25" high x 14.9" deep.

Model 319V: 17.12" wide x 19.4" high x 14.9" deep.

Shipping Weight:

FR310V: 80 lbs. / FR311V: 91 lbs. / FR319V: 92 lbs.

Accessories:

- See Page 11 for a complete list of available accessories.

Performance:

- 26 psi (1.79 bar) maximum pressure @ pump outlet.
- Up to 32.2 gallons (121.9 liters) per minute.
- Maximum viscosity of fluid pumped: #2 diesel fuel.
- Maximum Pump Operating Temperature: 150 degrees F (66 degrees C).
- Minimum Pump Operating Temperature: minus 20 degrees F (minus 29 degrees C) (note that operation at minus 20 degrees requires the "Arctic Nozzle" and "Arctic Hose" in the accessories section on page 11).
- Maximum Suction Lift: 10' (3 m) for gasoline; 18' (5.5 m) for #2 diesel fuel (the lift in feet is equal to the vertical distance from the surface of the fluid in the tank to the inlet of the pump, **LESS friction losses** through the vertical and horizontal runs of pipe, all elbows, and other fittings. System should be set up to require a **minimum** amount of suction lift).



IMPORTANT! All threaded connections on 300 series "M" suffix model pumps and meters are **BSPT standard threads**, **NOT** NPT standard threads as described elsewhere in this manual. Be sure to check the model tag affixed to the motor to be certain which model pump you have.

ATTENTION!

The following information is for suffix “E” pumps and meters (designed for use in Europe, Australia, Brazil, and New Zealand)! Refer to the information label applied to your pump to see if it is applicable.



Materials of Construction

Materials of construction of the external surface of the unit are: painted steel; painted cast iron; painted aluminum; zinc plated steel.

Materials of construction of the wetted parts are: cast iron; steel; zinc plated steel; 300 series stainless steel; bronze; carbon; ceramic; polyester; fiber; fluorocarbon; buna; 400 series stainless steel; aluminum.

Repair and Maintenance

Contact the place of purchase for warranty repair and maintenance.

Specific Conditions of Use

The M8 fasteners used for securing the stator housing shall be class 8.8. The M6 fasteners for securing the terminal cover compartments shall be Class 8.8.

An electrically conductive hose and nozzle shall be used with flammable fluids. To minimize static electricity build up keep the nozzle in contact with the container being filled.

Installation

Pump must be installed in compliance with EN 60079-14.

Certificates for Compliance of Safety have been obtained for the following agencies for products sold outside the US and Canada. Please refer to the tag on your particular product for its particular compliance data.



Warranty information is available at www.fillrite.com.