

# OWNER'S MANUAL

# 7000 SERIES SPRAYER

1350 Gallon Tank w/60', 80' or 90' Boom & Dual Option



## General Information

Thank You and Congratulations on purchasing your

Please read it carefully, as it furnishes information which will help you achieve years of trouble-free operation. All units can be custom equipped to meet all your spraying needs.



**WARNING:** To reduce the risk of injury, the user must read and understand the operator's manual before using this product.



**WARNING:** Cancer and Reproductive Harm  
[www.P65Warnings.ca.gov](http://www.P65Warnings.ca.gov)

**Any Questions, Comments or Problems: Call your nearest AG SPRAY Location and speak with one of our Friendly Technical Support Staff.**



[5194693 (05/23)]

BAKERSFIELD, CA 877-724-2236	COLUMBUS, NE 800-274-1025	DOTHAN, AL 800-227-4098	FARGO, ND 701-280-2862	HOPKINSVILLE, KY 800-637-7172	<b>VISIT US ONLINE @</b> <a href="http://WWW.AGSPRAY.COM">WWW.AGSPRAY.COM</a>
MANKATO, MN 507-388-6295	NEWTON, KS 800-394-7662	PASCO, WA 800-634-2026	TEMPE, AZ 877-974-7166		

## Table of Contents

3	Introduction
3-4	Pre-Operation Checklist
6-7	Sprayer Operation
8	Folding/Unfolding Procedure
9	Sprayer Start-Up Procedure
9-10	Plumbing Operation
10-11	Tank Rinse Operation
11	Spray Controller Operation
12	Sprayer Start-Up Procedure/Initial Start-Up
13	Trouble Shooting
16	Service & Maintenance
17	Break-In/Foam Marker
18	Greasing
19	Spray Control Valve Wiring/Filter Cleaning
20	Winterizing/Storage
21 -40	Parts Breakdowns
40	Hypro Warranty Info
41	Limited Warranty

# INTRODUCTION

1. Read and understand the Operators Manual and all safety signs before using.
2. Place all controls in neutral, stop tractor engine, turn monitor off, set park brake, remove ignition key, wait for nozzles to stop spraying before servicing, adjusting, or repairing.
3. Before spraying a field, be familiar with all potential hazards: trees, rocks, ditches, gullies, etc. Plan the spraying route to avoid hazards. Remember you are driving a wide machine. **USE CAUTION WHEN CORNERING.**
4. Keep hands, feet, hair and clothing away from all moving and/or rotating parts.
5. Do not allow riders on the sprayer or tractor during operation or transporting.
6. Clear the area of all bystanders, especially children, before starting or filling with water or chemical.
7. Stay away from wing pinch points when folding or extending wings. Keep others away.
8. Stay away from power lines when extending or folding wings. Electrocutation can occur without direct contact.
9. Read chemical manufacturers warnings, instructions and procedures before starting and follow them exactly.
10. Do not breathe, touch or ingest chemicals. Always wear protective clothing and follow safe handling procedures.
11. Spray only when potential for chemical drift is at a minimum. Even small amounts can affect neighboring crops or sensitive plants and people.
12. Dispose of chemical containers by triple rinsing them into the sprayer tank or thoroughly rinsing, crushing and delivering to regional disposal site.
13. In case of poisoning, get immediate medical attention.
14. Only rinse sprayer while still in the field. Spray the rinse thinly over the field already sprayed. Never contaminate the farmyard or drainage systems with sprayer rinse.
15. Do not eat in the field when spraying.
16. Before applying pressure to the hydraulic system, make sure all components are tight and that steel lines, hose and couplings are in good condition.
17. Before applying pressure to chemical system make sure that all connections are tight and that all hoses and fittings are in good condition.
18. Review safety instructions annually.

Before operating the Sprayer and each time thereafter, the following areas should be checked off:

# PRE-OPERATION CHECKLIST

1. Lubricate the machine per the schedule outlined in the "Maintenance Section".
2. Use only a tractor of adequate power and weight to operate the Sprayer.
3. Ensure that the machine is properly attached to the tractor. Be sure that a mechanical retainer is installed through the drawbar pin and the safety chain is attached to the drawbar cage. Jack is properly stowed on bottom side of the tongue.
4. Check the hydraulic system. Ensure that the hydraulic reservoir in the tractor is filled to the required specifications.
5. Inspect all hydraulic lines, hoses, fittings and couplers for tightness. Use a clean cloth to wipe any accumulated dirt from the couplers before connecting to the hydraulic system of the tractor.
6. Check the tires and ensure that they are inflated to the specified pressure.
7. Calibrate the sprayer if it is the start of the season or a new chemical is being used. Calibrate as specified in rate control manual.
8. Check the condition and routing of all chemical hoses and lines. Replace any that are damaged. Re-route those that are rubbing pinched or crimped.
9. Check the spray pattern of each nozzle. Remove and clean or replace any that have an unusual pattern.
10. Remove the steel mesh line filters and wash with clean water. Reinstall.
11. Check that all connections in the electrical system



are connected and tight.

12. Remove delivery bolt (Figure 2) on breakaway clamp and ensure wing breaks away freely and returns to locked position. (Delivery bolt should not be reinstalled, for delivery safety only)
13. Consult tractor manufacturers manual for hydraulic operation system. (open or closed center system) For closed center systems, leave hydraulic boom operation block located on the center of boom as factory installed (Figure 4). For open center hydraulic systems, the by-pass (dump) valve needs to be put back in the place of the by-pass (dump) plug (Figure 3).

### CONVERTING CLOSED CENTER TO OPEN CENTER HYDRAULIC SYSTEM

- \* Standing behind the center of the sprayer looking toward the tractor locate the boom folding hydraulic block .
  - \* Locate the by-pass (dump) valve (Figure 4) on the right hand side and the by-pass (dump) plug on left hand side.
  - \* Remove both plug and valve.
  - \* Reinstall by-pass valve on left hand side and plug on right hand side.
  - \* Plug in by-pass valve into 2 pin connector.
14. Inspect boom alignment.
    - \* The boom is equipped with set bolt adjustments to provide a means to adjust alignment.
    - \* With the boom in field spraying position look down the sprayer boom from end to end and adjust alignment bolts as needed at each hinge.
    - \* 6 points should be inspected annually.
    - \* Left and right inner boom (Figure 5)
    - \* Left and right outer boom (Figure 6)
    - \* Left and right break away (Figure 7)

To adjust, loosen jam nut, turn position bolt to the required position and retighten jam nut.

Figure 1



Figure 2



Hypro Cast Iron Pump w/Integrated PWM Valve





# OPEN CENTER SYSTEM

Figure 3

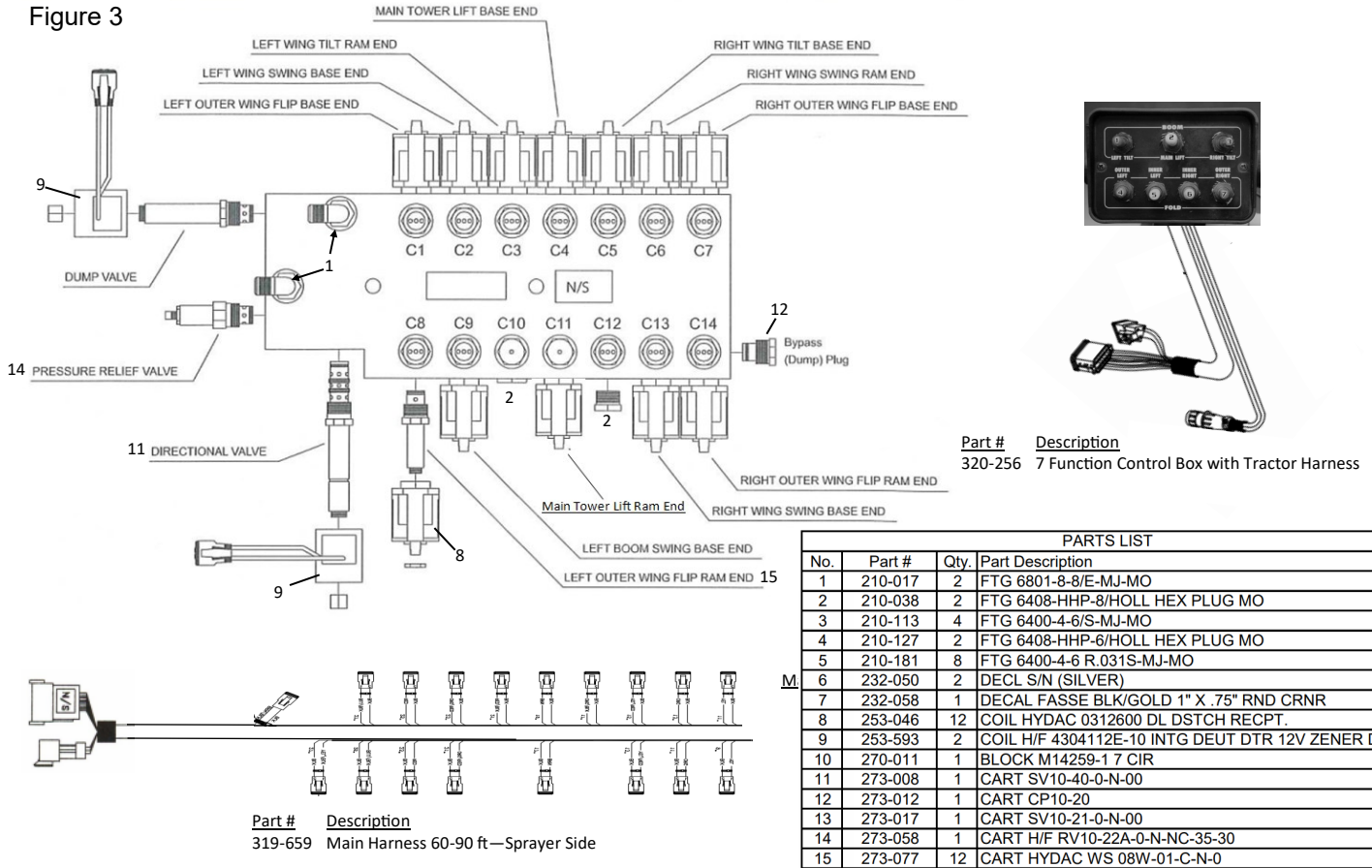

# CLOSED CENTER SYSTEM

Figure 4

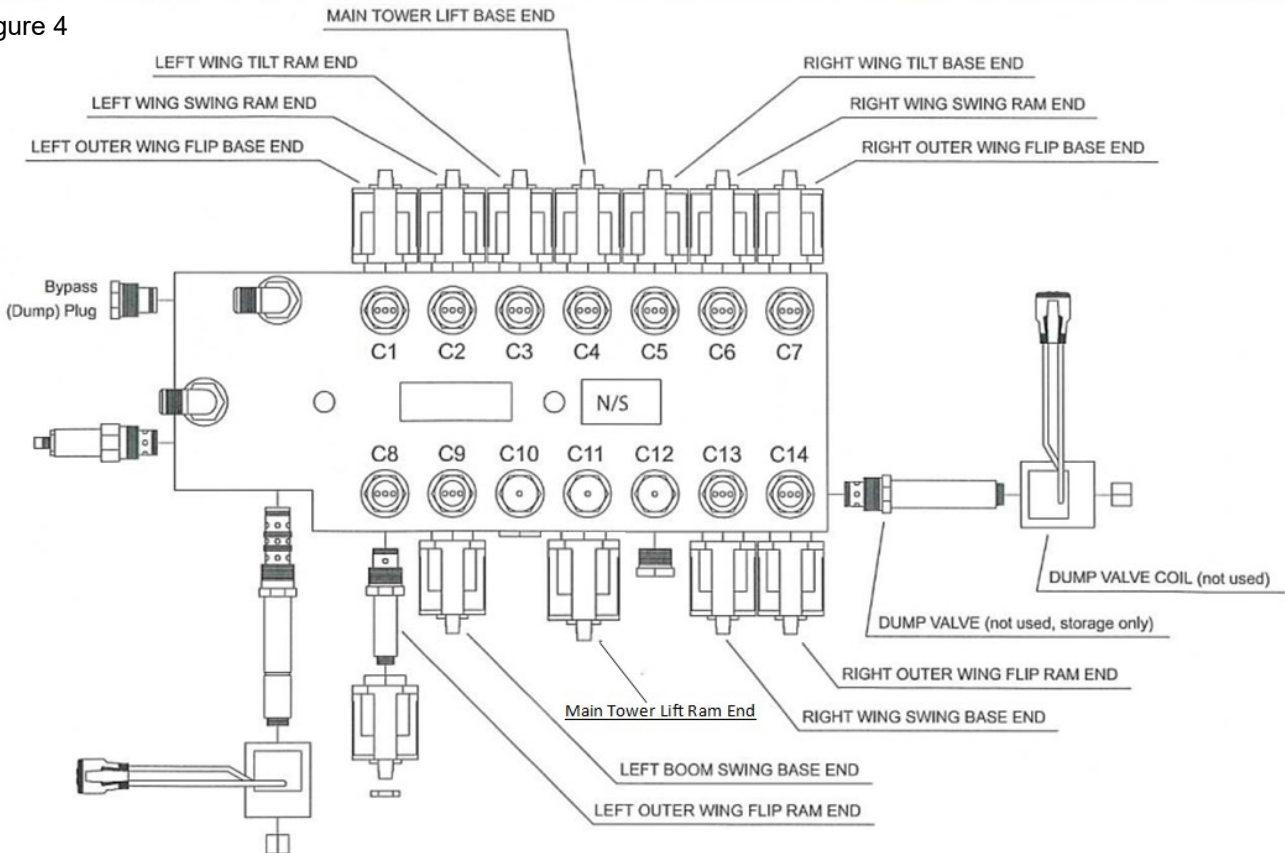

# SPRAYER OPERATION

Figure 5

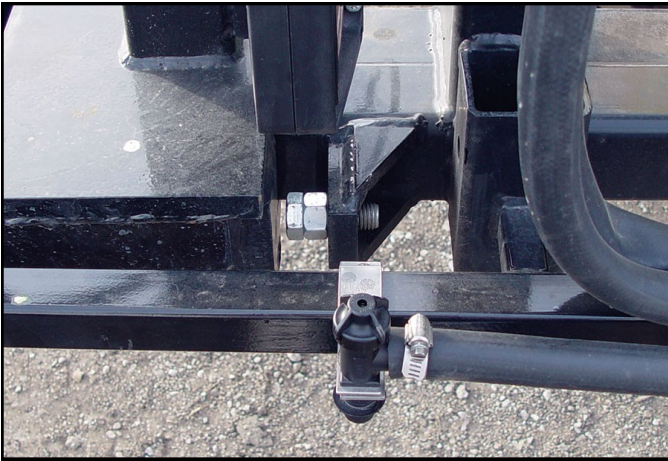

Figure 6



Figure 7



## **\*\*CAUTION\*\***

### **DO NOT PULL AT ROAD SPEEDS WITH PRODUCT IN MAIN TANK**

Electrocution hazard. Keep away from power lines. To prevent serious injury or death from electrocution:

1. Stay well away from power lines when folding or extending wings. Electrocution can occur without direct contact.
2. Lower wings completely before moving or transporting.

## **BOOM OPERATION**

\* Mount 7-function control box in a convenient place for easy operator access. Attach to a 12 volt power source (supplied with convenience tractor power plug). Route control cable through tractor cab and plug connectors together and route wiring harness across hitch.

\*Be sure there are no power lines next to the machine and the sprayer is located in an open area enough to allow the booms to swing out and fold over without hitting any obstructions. The hydraulic circuit control lever to the boom function circuit must be placed in positive flow position prior to operating. The boom circuit only requires 3 gpm of hydraulic flow. Set hydraulic flow accordingly, increasing hydraulic flow will not speed up boom function. Only reduce sprayer pump and tractor performance.

### **1. LEFT BOOM TILT POSITION:**

This spring-loaded-to-neutral-center toggle switch controls the left boom tilt function. Move the switch up and hold to raise the tip of the left boom and down to lower. Release the switch, the left boom will stop moving and it will remain in position. Use this function to raise the tip of the boom to clear obstructions.

### **2. BOOM UP/DOWN:**

This spring-loaded-to-neutral-center toggle switch controls the boom height cylinders. Move the switch up and hold to raise the entire boom assembly. Move the switch down and hold to move down. Release the switch, the boom will stop and remain at that position. To ensure optimal boom performance never run boom in fully down position. Doing so eliminates boom ride accumulator.

Note: Once tower cylinder bottoms out raise 1" for lowest recommended sprayer height.



# SPRAYER OPERATION CONTINUED

Figure 8



This spring-loaded-to-neutral-center toggle switch controls the right outer boom function. Move the switch up and hold to pivot the right outer boom in and down to extend. Release the switch, the right outer boom will stop moving and it will remain at that position.

## 7. RIGHT BOOM EXTEND/FOLD:

This spring-loaded-to-neutral-center switch controls the right boom position. Move the switch up and hold to fold the right boom and down to extend. Release the switch, the right boom will stop moving and it will remain in that position.

### **\*\*IMPORTANT\*\***

Extend the cylinder completely when extending the outer boom to eliminate outer wing vibration. To insure the wing is locked down hold the toggle switch down for 5 seconds after the boom is fully extended.

## 3. RIGHT BOOM TILT POSITION:

This spring-loaded-to-neutral-center toggle switch controls the right boom tilt function. Move the switch up and hold to raise the tip of the right boom and down to lower. Release the switch, the right boom will stop moving and it will remain in position. Use this function to raise the tip of the boom to clear obstructions.

## 4. LEFT BOOM FOLD/EXTEND:

This spring-loaded-to-neutral-center toggle switch controls the left boom position. Move the switch up and hold to fold the left boom and down to extend. Release the switch, the left boom will stop moving and it will remain at that position.

### **\*\*IMPORTANT\*\***

Extend the cylinder completely when extending the outer boom to eliminate outer wing vibration. To insure the wing is locked down hold the toggle switch down for 5 seconds after the boom is fully extended.

## 5. LEFT OUTER BOOM SWING:

This spring-loaded-to-neutral center toggle switch controls the left outer boom pivot function. Move the switch up and hold to pivot the left outer boom in and down to pivot out. Release the switch, the left outer boom will stop and remain at that position.

## 6. RIGHT OUTER BOOM SWING:

Figure 9





# Folding/Unfolding Procedure

## UNFOLDING BOOM FOR FIELD USE

### \*\*CAUTION\*\*

Electrocution hazard. Keep away from power lines. To prevent serious injury or death from electrocution:

1. Stay well away from power lines when folding or extending wings. Electrocution can occur without direct contact.
2. Lower wings completely before moving or transporting.

**Note: Tractor should come to a full stop before folding or unfolding sprayer. Make sure clear of any obstacles overhead or around sprayer that could come in contact with boom.**

1. Before unfolding boom, remove transport using lock pins and tower cylinder transport stop (Figure 1). Reinstall lock pins and tower stop before transporting sprayer.
2. Raise tilt cylinders by pushing up on "tilt" toggle switch to raise boom out of transport saddle.
3. Hold down on outer fold switches to fold-over outer wings to spray position. Note: Extend the cylinder completely when extending the outer boom to eliminate outer wing vibration. To ensure the wing is locked down hold the toggle switch down for 5 seconds after the boom is fully extended. (Figure 9)
4. Hold down on "main lift" boom switch to lower boom to desired spray height. To ensure optimal

boom performance never run boom in fully down position. Doing so eliminates boom ride accumulator.

5. Reverse the above procedure when converting from field to transport configuration.

**IMPORTANT: Once tower cylinder bottoms out raise 1".**

**WARNING: Outer fold Booms are a vertical fold and once wing goes past 90° if Air is present in hydraulic system the wing could gravity free fall causing possible personal or boom damage.**

The sprayers are hydraulically charged at the factory, but the following procedure should be followed on an annual basis to prevent possible boom drop, from transport position, raise "tilt" wings out of transport saddle, swing the "inner" fold booms 45° out from sprayer frame. Raise "outer" fold wings 80° from inner wing, lower "outer" fold wings to saddle transport position. Repeat 3 times. This cycles the hydraulic lines to prevent air pockets in the hydraulic system to prevent "boom drop".

Figure 10



# PLUMBING OPERATION

Figure 11

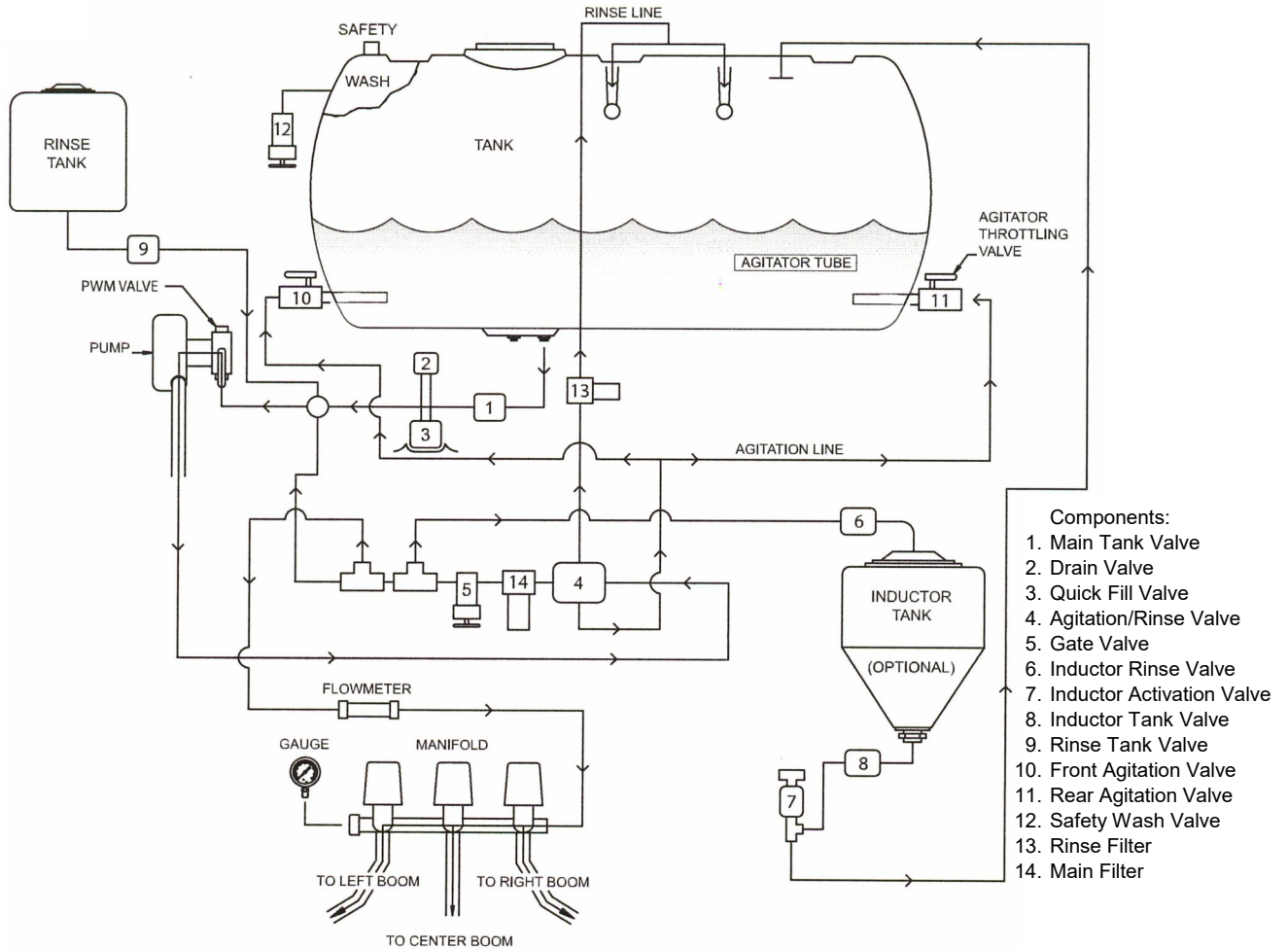

1. Connect supply hose to quick fill valve (valve 3) (If top filling, open lid and insert supply hose.)

**“WARNING!” Be careful if crawling on sprayer. Steel surfaces can become slick when wet. Also watch head while climbing onto sprayer if in transport position. Operator must go under boom to access platform.**

2. Make sure main tank valve (valve 1) is open. NOTE: Make sure rinse tank valve (valve 10) is closed before filling. Rinse tank could over run and become chemically contaminated otherwise.
3. Open supply valves and quick fill valve (valve 3) and start filling sprayer.
4. Start sprayer pump and begin circulating solution. (NOTE: make sure sprayer booms are off) Make sure Agitation/Rinse valve is turned with Arrow pointing downward for agitation and agitation valves (valve 11 and valve 12) are open.
5. Make sure manual pressure gauge located on

sprayer hand rail has a minimum of 40 PSI and not to exceed maximum of 85 PSI while filling.

6. With a minimum of 1/2 tank of solution begin to add chemical.

### OPTIONAL INDUCTOR:

Pull transport pin, release Safety latch and gently lower to bottom position. Open Inductor activation valve (valve 8) to start venturi vacuum. Add pre-determined chemical amount to inductor tank and then open inductor tank valve (valve 9) to allow chemical to be pulled into sprayer. (for dry or heavy viscosity products once premeasured, add some solution by opening inductor rinse valve (valve 7) 1/8 turn or as needed to make into a slurry for more efficient induction.) Once chemical has been drawn out open inductor rinse valve (valve 7) 1/4 turn or as needed to rinse chemical residue down for 1 minute or as needed. Close inductor rinse valve (valve 7) once tank is empty close inductor tank valve (valve 9). Repeat above until all chemical is added. When done adding all chemical for spray solution close inductor activation valve (valve 8) and raise inductor tank to transport position, activate safety latch, insert transport pin.



## PLUMBING OPERATION CONTINUED

**NOTE:** For inducing dry flowable products, adjust PWM valve (Pulse width modulation) to 60 P.S.I. minimum.

**NOTE:** Graduation marking on inductor tank are not calibrated. Do Not Use for measuring chemical. Only to be used as a reference point.

**NOTE:** Make sure inductor rinse tank valve (valve 7) is closed at all times other than when adding chemical.

7. All chemical needs to be added before solution level reaches 3/4 of desired capacity.

**NOTE:** Follow all chemical manufacture label instructions.

8. When solution reaches desired tank level, close

Figure 12



quick fill valve (valve 3) and/or stop solution from being added to sprayer. Disconnect supply hoses, secure all sprayer covers.

9. Continue to run sprayer pump to circulate sprayer solution.
10. Fill auxiliary tanks as needed.
  - Rinse
  - Safety wash
  - Foam Marker
11. Allow solution to circulate for several minutes before applying.

### Sprayer Controls (Figure 12)

- |                                |   |
|--------------------------------|---|
| a. Sprayer Controls Rinse      | e. Clean Water Hand Rinse Tank                                |
| b. Sprayer Controls Agitation  | f. Main Tank Fill Valve (2" Quick Fill)                       |
| c. Sprayer Controls Rinse Tank | g. Rinse Tank Fill Valve (2" Quick Fill)                      |
| d. Sprayer Controls Main Tank  | h. Main Tank Shut Off Safety Valve (Under Tank. Not Pictured) |



## TANK RINSE OPERATION

Fresh water rinse tank located behind the main tank is designed to allow the operator to rinse the sprayer without having to leave the field.

1. Make sure sprayer pump is off.
2. Turn spray control valve from Spray Tank to Rinse Tank. (valve 1)
3. Turn spray control valve from Agitation to Rinse Tank (valve 10)
4. Turn pump on make sure boom valves are off. Manual pressure gauge on front of the sprayer needs to read between 50 and 75 PSI (see sprayer controls for adjustment procedure)
5. After allowing sufficient time for agitation lines to rinse then turn agitation/rinse valve (valve 4) 1/2 turn so arrow points upward to activate rinse balls.
6. Run pump until rinse tank is empty.
7. Shut pump off.
8. Turn spray control valve from Rinse Tank to Spray Tank (valve 10)

9. Turn spray control valve from Rinse Tank to Agitation (valve 1)
10. Turn agitation/rinse valve (valve 4) 1/4 turn so arrow points horizontal and both lines are off.
11. Lightly spray rinse solution over pre-sprayed area.
12. Shut off pump and booms when tank is empty.
13. Repeat as needed when changing chemicals.

**NOTE: Recommendation that a chemical neutralizer be run through the rinse system between different chemical usages. Follow procedures stated above. Rinse with water following chemical neutralizer before adding chemical.**

OPTIONAL: Rinse Boom plumbing while chemical still in tank.

- 1a. Close agitation/rinse valve (valve 4) to horizontal position (shutting off both lines).
- 2a. Start sprayer pump, open boom valves and dispense lightly over pre-sprayed area.
- 3a. Run until adequately rinsed.

## SPRAY CONTROLLER OPERATION

1. See spray controller manufactures manual for proper installation and setup.
2. Once controller is installed according to manufactures recommendations test the system with water.
3. Add a couple hundred gallons of water unfold boom in a safe area according to folding/unfolding procedures.
4. Engage pump per pump operation.
5. Turn master boom switch to the on position.
6. Turn individual boom switches on one at a time cycling on and off to make sure each is operating properly.
7. With master switch on and all individual boom switches on, cycle pressure up and down (in manual mode if using an automatic rate controller) to determine spraying pressure range.
8. Repeat #7 with master switch on and individual booms off. This may be required to be done to attain recommended PSI for proper operation of optional inductor tank and rinse system.

## SPRAYER START-UP PROCEDURE

1. Start with water (fill tank).
2. Make sure hydraulic lines are in correct port.
3. PWM valve has a cap on top. Remove cap and screw set screw all the way down to put pump in manual mode.
4. Make sure pump is primed. Pump is primed by opening different strainer bowls and let water flow out. Reassemble strainer bowl.
5. Make sure the proper valves are open on control panel. The large handle pointed in spray position and the small valve says "rise tank and agitation" is pointed to agitation.
6. Go to monitor, with controller in manual, booms off and master switch on. Press and hold the increase for 10 seconds or pressure starts to rise.
7. Once the system is spraying correctly in manual mode, shut system down.
8. Go to PWM valve on pump, remove cap and turn set screw all the way to up position and replace cap.
9. Return to monitor and set to Rate 1 or auto, with booms on and master off (if using a Raven 440 or 450). Enter a self test speed by hitting self test, enter, the speed you wish to travel and enter again.
10. Start pump.
11. Turn master on. You should be hitting your desired rate. If not, redo steps 6 - 11.
12. You should be ready to spray.

**NOTE: Remember the Raven 440 and 450 have a feature called "zero speed shutoff" which means if tractor is not moving in rate 1 or 2 and the master switch gets turned on, you will lock the monitor up. If this happens, reenter self-test speed and test again. Make sure you are moving before master switch is turned on, in automatic mode.**

**NOTE: If pressure does not rise, the pump is probably not primed correctly. Recheck the valves are open.**

## Initial Start-Up

1. Follow label instructions for proper mixing of foam concentrate. Fill tank with desired amount of water and then add foam according to label. It is better to have more foam concentrate added to the water than less, because liquid flow amount can be regulated by Wet/Dry knob.
2. To start foamer: turn main power switch to on position then switch the toggle switch to the left or right position. Foam will travel from the control valve (144f-1-3) toward the right or left side of the boom. Reverse the L/R toggle switch and foam will travel the opposite direction. (Figure 13)

**NOTE: Start with control knob at center position.**

**NOTE: If liquid pump does not prime on start up, run Wet/Dry control at full wet until prime.**

# TROUBLE SHOOTING

1. If foam is soupy, set more to dry on foamer control or more foam concentrate needs to be added to the water (concentrates for pressurized tank systems are not recommended for use with SI foam markers)
2. Water conditions (soft or hard) will also vary foaming action Your local coop will probably be able to advise which foam concentrate works best with local water conditions.
3. If a change of drop rate is desired: adjust knob more toward wet until desired rate is achieved.
4. Drops are too far apart or you are doing post

emerge work and can not see drops do to plant height: Remove rubber boot from end of drop hose to get a nearly straight stream of foam at end of boom.

**NOTE: If you are having trouble seeing foam try either Tracer Pink (hot pink) or Tracer Blue colorants from Ag Spray Equipment.**

Figure 13

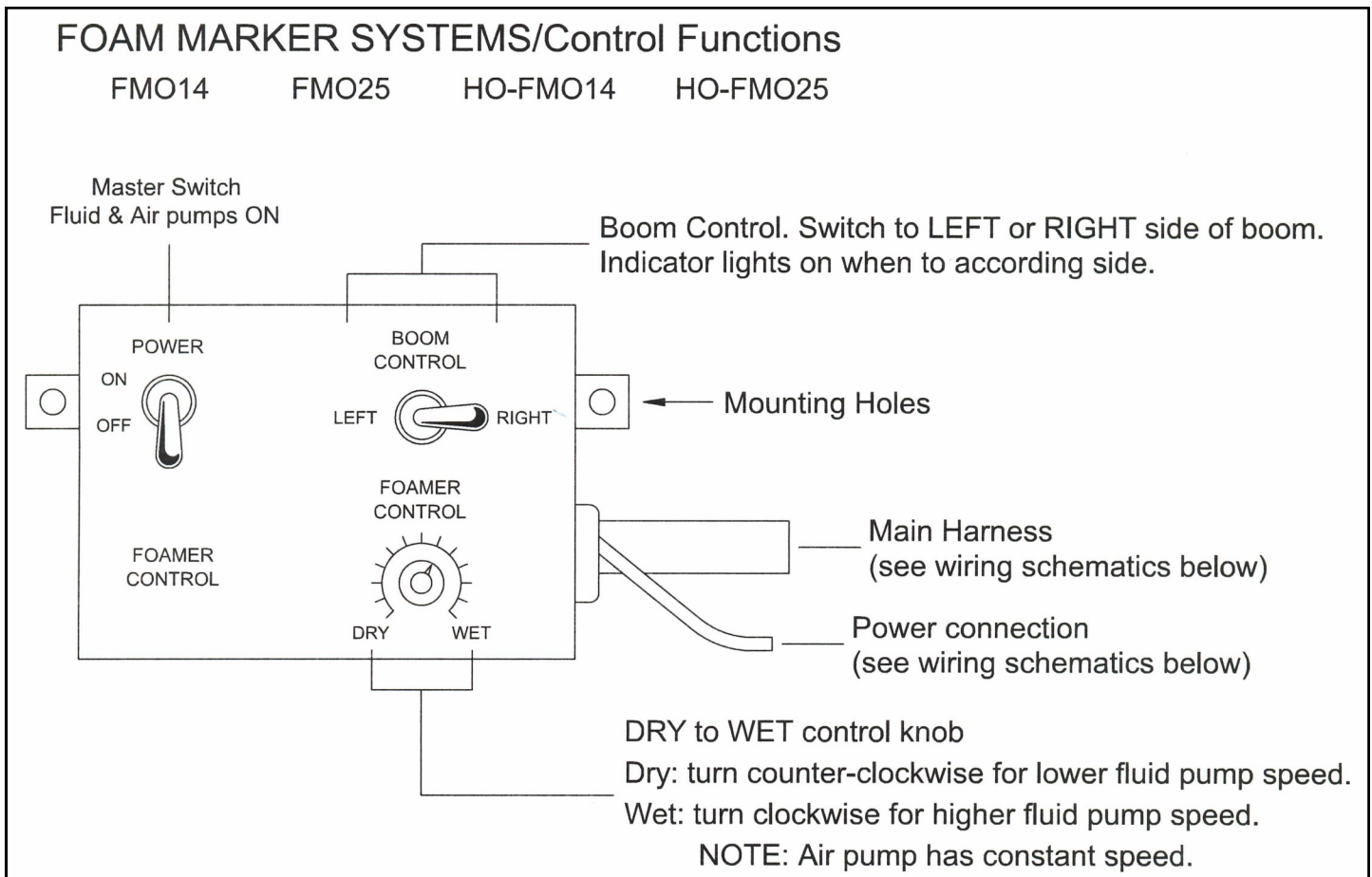



## 440/450 RAVEN CONTROLLER WITH PWM SETUP

1. Install Raven 440 or 450 control console and hook up to sprayer (see instructions inside controller box).
2. Turn on control console.  
**When making selections/entering numbers, always be sure to press enter to save your settings.**
3. Make the following selections when prompted:
  - Units US (Enter)
  - Speed sensor 2 "SP2" (Enter)
  - Valve type C-P "Closed PWM" (Enter)
4. Select Boom Cal "Raven 440, 1-3", "Raven 450, 1-5"
  - Enter number of inches covered for each section (not full width of boom).  
To find the number of inches covered, multiply the number of nozzles per section and the number of inches between nozzles. (Ex. Section one; 12 nozzles x 20 inch between nozzles =240 inches)
5. Select Speed Cal
  - Enter 783 (This is the cal number for a Garmin GPS Sensor).
6. Select Meter Cal-Enter the meter cal number which is printed on the tag for on your Flow Meter. (ex. 720)
7. Select Valve Cal
  - Enter 43 (This is only for use with the PWM controlled hydraulic pump).
8. Select Rate 1
  - Enter the number of gallons/acre you want to spray in Rate 1. (ex. 10.0)
9. Select Rate 2-Enter the number of gallons/acre you want to spray in Rate 2. (ex. 20.0)
10. Select DATA MENU
  - Scroll to PWM Frequency and enter 110.
11. Hold SELF TEST
  - This will scroll through all settings to make sure everything is entered.
  - If all cal numbers are entered, it will stop scrolling after a few seconds. (move to step 12.)
  - If any cal numbers have not yet been entered, it will keep scrolling. (If so, you will need to go back through your cal numbers and make sure they are all entered correctly.)
12. Turn the Flow Control to MAN for manual control, turn the Booms all to the off position and turn the master on.
13. Hold INC to build pressure. This will allow you to check any leaks and use your inductor tank (if applicable) while sitting. **BE AWARE NOT TO OVER PRESSURIZE SYSTEM**
14. TO SPRAY
  - Turn the Flow Control to Rate 1 or Rate 2 (preference).
  - The speed you need to travel is dependent on the rate at which you are spraying.

## 2630 JD RATE CONTROLLER WITH PWM SETUP

1. After hooking up all wiring between tractor and sprayer, turn the system on.
2. Make sure all nozzles are open with desired tips installed.
3. From the Menu, select Rate Controller
4. Setup your Implement type
  - Select Pull Behind Sprayer, enter a name and tank size.
5. Select the Setup Tab (right)
6. Select the Implement Tab (top)
  - Enter your boom width
  - Adjust the width of each section
  - Be sure to enter any Fence Row(s) if applicable
7. Select the System Tab (top)
  - Section Valve type – 3 wire
  - Constant Flow – no
  - Control Valve Type – PWM
8. Select PWM Setup
  - Control Valve Calibration – 2743
  - Coil Frequency – 110
  - High Limit – 100
  - Low Limit – 1
9. Select Calibrate PWM
  - Turn Master ON and press Start
  - Decrease if necessary to make sure Low limit is at or around 1 gal/min. Set Low Limit
  - Increase if necessary to make sure High limit is at or just below max pump rotation or 80 psi. Set High Limit and turn off Master.
  - If you return to PWM Setup it may show new numbers in the High Limit and Low Limit.
10. Setup your Flowmeter
  - Flowmeter Calibration – Enter the Flowmeter cal. number located on your flow meter.
  - Flowmeter Units – 10 Gal.
11. Select the Rates Tab (top)
  - Set your rates at gal/acre.
12. Select the Diagnostics Tab (right)
  - From the dropdown menu under the Tests tab, select Nozzle Flow Check
  - Enter your desired speed into the Test Speed
  - Enter your desired Gal/Acre into the Rate
  - Turn the Master on and press Start to test  
(At this point you can see the system will adjust its self to run at the desired speed while you are not driving.)

## OPTIONAL SPRAY CONTROLLER SPEED SENSOR

Figure 14

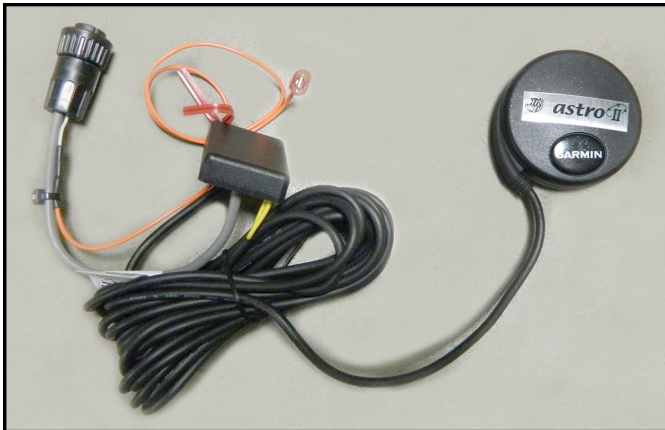

If equipped with an automatic rate controller, a speed sensor is sent along in the controller kit. The sensor needs to be mounted to the cap or sprayer with a clear line of sight to the sky. The red wire will need to be hooked up to 12 volt power. See rate controller operation manual for specific calibration numbers (Figure 14).

## LADDERS

Figure 15



Raise the ladder into the vertical position and push over and down to secure in the locked position. The lock is part of the ladder anchor bracket. Position the ladder in the up and locked position whenever the sprayer will be moved (Figure 15).

## SERVICE & MAINTENANCE

1. Review the Operator's Manual and all safety items before working with, maintaining or operating the sprayer.
2. Place all controls in neutral, stop the tractor engine, turn monitor off, set park brake, remove ignition key, wait for nozzles to stop spraying before servicing, adjusting, repairing or unplugging.
3. Follow good shop practices:
  - Keep service area clean and dry
  - Be sure electrical outlets and tools are properly grounded
  - Use adequate light for the job at hand.
4. Before applying pressure to a hydraulic system, make sure all components are tight and that steel lines, hoses and coupling are in good condition.
5. Before applying pressure to chemical system, make sure that all connection are tight and that all hoses and fittings are in good condition.
6. Relieve pressure from hydraulic circuit before servicing or disconnecting from tractor.
7. Keep hands, feet, clothing and hair away from all moving and/or rotating parts.
8. Clear the area of bystanders, especially children, when carrying out any maintenance and repairs or making any adjustments or filling.
9. Place stands or blocks under the frame before working beneath the machine.
10. Wear safety goggles, neoprene gloves and protective clothing when working on the sprayer filled with active chemical.
11. Wash machine to remove all chemical residue before working on unit. Wear appropriate protective gear at all times.
12. Protect yourself from chemical contamination.



# BREAK-IN

Although there are no operational restrictions on the sprayer when used for the first time, it is recommended that the following mechanical items be checked:

## A. After operating for 1/2 hour

1. Re-torque all the wheel bolts.
2. Re-torque all other fasteners and hardware.
3. Check that all electrical connections are tight.
4. Check that no chemical or hydraulic lines are being pinched or crimped. Re-align as required.
5. Check that all nozzles are working properly. Clean or replace as required.
6. Lubricate all grease fittings. (Figure 17 & 18)

## B. After 5 hours and 10 hours of operation

1. Re-torque all wheel bolts, fasteners and hardware.
2. Check chemical and hydraulic line routing.
3. Check that all nozzles are working properly.
4. Then go to the normal servicing and maintenance schedule as defined in the Maintenance Section.

## FOAM MARKER WINTER STORAGE

1. When unit is stored during freezing temperatures, drain unused foam solution from tank (disconnect air pump and run liquid pump until unit is near empty), fill tank with enough foam marker anti-freeze to cover bottom of suction hose. Then run unit until antifreeze is going into pvc mixing chambers.

Figure 16

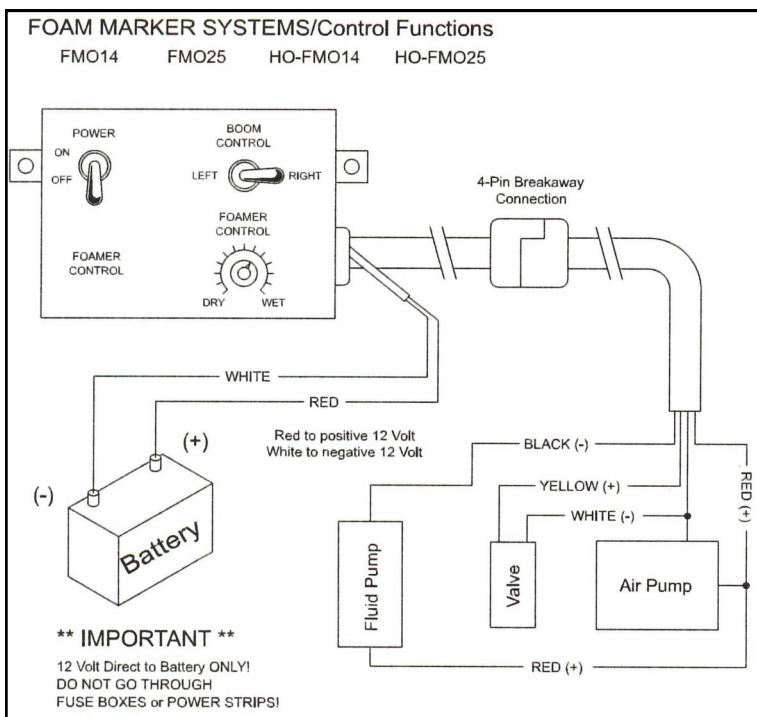

## OPTIONAL FOAM MARKER OPERATION

1. Route the 20' split harness and control box to the operator's desired location. **\*\*Make sure the cable does not contact any hot, sharp or moving objects to avoid shorts and breaks\*\***
2. Connect the red and white wires directly to the battery. **DO NOT CONNECT** the power wires through any fuse or switch boxes on the tractor, this will cut down on amps to the marker (Figure 16).

\* On units with 12 volt batteries, contact the red lead to the positive post and the white lead to the negative post.

\*\* On units with two 6 volt batteries, connect the red lead to the positive post that feeds the starter and the white lead to opposite battery ground.

# GREASING

1. Wipe grease fitting with a clean cloth before greasing to prevent injecting dirt and frit into joint.
2. Replace and repair broken fittings immediately.
3. If a fitting will not take grease, remove and clean thoroughly. Also clean lubricant passageway. Replace fitting if necessary.

**\*Note: Grease 18 points 8 hours or daily.**

Figure 17



## L/R GREASE LOCATIONS

Apply adequate grease to the following:

- |                         |  |
|-------------------------|--|
| 1. L/R Breakaway Hinge  | 4. L/R Center Section Bushing (Lower)                                |
| 2. L/R Outer Boom Hinge | 5. L/R Center Section Bushing (Upper)                                |
| 3. L/R Inner Boom Hinge | 6. Parallel Hinge Bushings (Total of 8) (4 Top Pins & 4 Bottom Pins) |

Figure 18

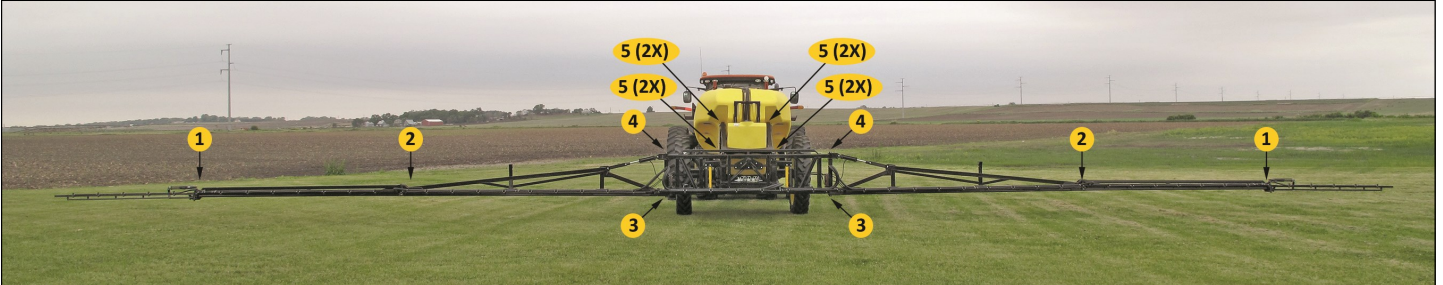

Figure 19

							<b>Controller Wiring Diagram</b>
<u>12 V+</u>	<u>Ground</u>	<u>Section 5</u>	<u>Section 4</u>	<u>Section 3</u>	<u>Section 2</u>	<u>Section 1</u>	
Red	Black	Gray	Yellow	Green	Brown	White	TeeJet 844 & 854
Red	Black	-	-	Orange	Yellow	Green	TeeJet 734 & 744
Red	White	-	-	Blue	Brown	Black	Raven 330 & 440
Red	White	Wht/Brwn	Black/Wht	Blue	Brown	Black	Raven 440 & 450

## SPRAY CONTROL VALVE WIRING

1. The motorized ball valves equipped on the sprayer require 12V<sup>+</sup> constant power and ground to make actuate. When 12V<sup>+</sup> is sent from the controller thru the signal wire per each section the valve will open as long 12V<sup>+</sup> is present to the section wire. Once power is removed by turning off the individual or master switch, the valves will close.
2. Each motorized ball red wire connects to the 12V<sup>+</sup> terminal. Each motorized ball valve black wire will connect to ground terminal, and each motorized ball valve white wire will connect to the corresponding section terminal.

## FILTER CLEANING

The fluid in the sprayer is continually being filtered through a screen filter. The sprayer must have clean water to prevent clogging of the screens and check valves when in use. These screens must be cleaned daily or more often as required. To clean, follow this procedure:

1. At the start of each day before the water and chemicals are added, the screens should be checked and cleaned.
2. If there is water or solution in the sprayer, close valve 1 and valve 4 (Figure 21) to isolate the screens.
3. Loosen the filter bodies by hand. Do not use a wrench as this could damage the filter body.
4. Remove the screens and inspect them for foreign material.
5. Clean them using clean water.
6. Inspect for holes or tears. If there is damage, replace.
7. Install the screens and body to the filter heads and tighten by hand. Do not use a wrench as this might damage the body. Do not overtighten and crack the head.
8. Open valves 1 & 4 to allow the solution to circulate.
9. Drain all screens before storage to avoid freezing.

Figure 20



Figure 21



## SUGGESTED WINTERIZING PROCEDURE

1. Drain all fluids from sprayer strainers, nozzles, etc.
2. Pour approximately 15 gallons of RV antifreeze in rinse tank

**Note: Do not forget to pour 1 gallon into main tank and inductor.**

3. Repeat steps 3-7 on start up procedure with the exception of pulling antifreeze from rinse tank instead of main tank.
4. Make sure to turn on valve that is coming off of flow back ball valves. This valve should be in the On position when winterizing to clean out on/off valves.
5. Once you have sprayed RV antifreeze through all

nozzles, drain all water and antifreeze out.

6. It is always a good idea to take apart manifold clamps to drain water and antifreeze out.

### WINTERIZING CHECK LIST

- |  |   |
|--|---|
| <input type="checkbox"/> Flowback Valves | <input type="checkbox"/> Inductor             |
| <input type="checkbox"/> Pump            | <input type="checkbox"/> Rinse Tank           |
| <input type="checkbox"/> Rinse Balls     | <input type="checkbox"/> Feed Lines & Nozzles |
| <input type="checkbox"/> Hand Wash Tank  |   |

## REMOVING FROM STORAGE

When removing from storage and preparing to use, follow this procedure.

1. Clear the area of bystanders, especially small children, and remove foreign objects from the machine and the working area.
2. Check
  - a. Tank for cracks
  - b. Tank hold down hardware
  - c. All hardware. Tighten as required.
  - d. Tire pressure.
  - e. All sprayer and hydraulic lines, fittings and connections. Tighten as required.
3. Lubricate all grease fittings.
4. Replace any defective parts.

5. Fill the tank with 20 gallons (75 liters) of clean water and run for 5 minutes in the wash cycle. Open and close all valves several times. Flush water through the booms.
6. Repeat step 5.
7. Calibrate the pump, nozzles and sprayer before using.
8. Go through the pre-field checklist before using.



# 1350 Sprayer Frame

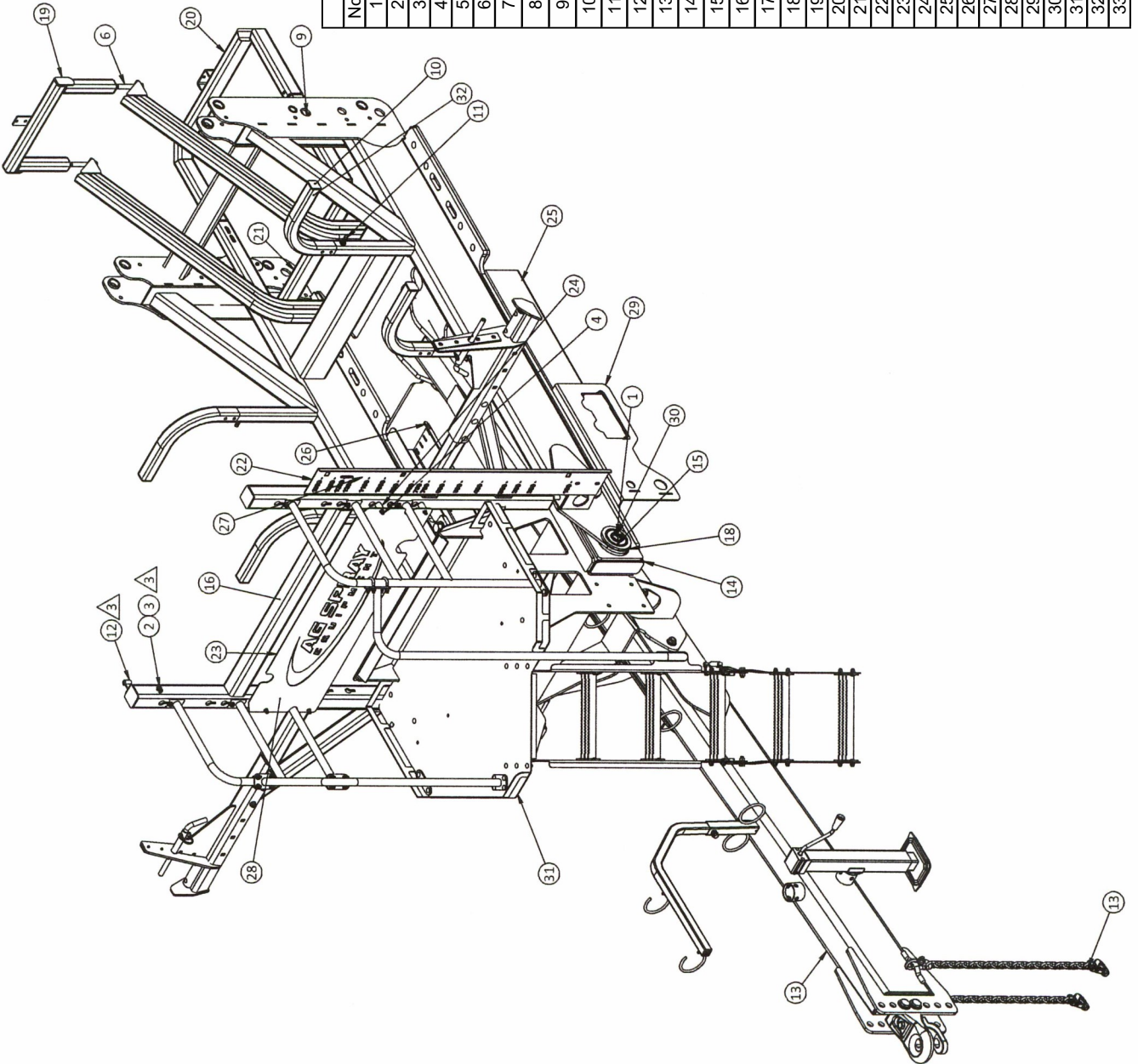

PARTS LIST		
No.	Part #	Qty. Part Description
1	5006363	10 1"-8nc Hex Flanged Toplock Nut Gr. 8
2	5006366	5 3/8"-16nc Hex Flanged Toplock Nut Gr. 8
3	5034482	1 3/8"-16nc x 1" Carriage Bolt
4	5034544	4 3/8"-16nc x 2 1/2" (Full Thread) Carriage Bolt
5	5034690	4 H.H.C.S. Flanged 1/2"-13nc x 1"
6	5034743	2 Flng HH Bolt 3/4-10 x 6"
7	5034751	6 Flng HH Bolt 1-8 x 2 1/2"
8	5034755	2 Flng HH Bolt 3/4-10 x 3 1/2"
9	5034777	4 Flng HH Bolt 3/8-16 x 2 1/2"
10	5046445	4 Tube Cap, 2 x 2 x 3/16" Wall
11	5117104	4 S.H.S.S. 1/2-13nc x 1 1/2" Long Cup Pt.
12	5278719	1 Gauge Mount Bracket
13	5279137	1 Large Sprayer Tongue Assembly
14	5279243	1 Frame Weldment
15	5279372	4 Applicator Gooseneck Attach Pin Widmnt
16	5279375	1 1350 Tank Hold Down Widmnt
17	5279381	1 Large Tank Hold Down Attach (RH) Widmnt
18	5279382	1 Large Tank Hold Down Attach (LH) Widmnt
19	5279388	1 Large Tank Rear Hold Down
20	5279390	1 Large Sprayer Rinse Tank Rest Widmnt
21	5279391	1 Rinse Tank Base Mount Widmnt
22	5280025	1 1350 Sight Gauge Angle w/Graduations
23	5280572	1 1350 Hand Wash Tank/Logo Sheet
24	5280573	4 Spacer Hand Rinse Tank Tube
25	5280575	1 Large Sprayer Hose Carrier (LH)
26	5280576	1 Large Sprayer Hose Carrier (RH)
27	5280584	1 Sight Gauge Upper Mount Bracket
28	5280600	1 1350 Hand Rinse Tank Hold Down Plate
29	5280709	1 Large Quickfill Panel Widmnt
30	5280803	2 Large Sprayer Gooseneck Attach Widmnt
31	5280819	1 1350 Sprayer Steps & Ladder Assembly
32	5280885	4 Tank Support Weldment
33	5280897	2 7000/8000 Series Boom Rest Assembly



# Center Section Assembly

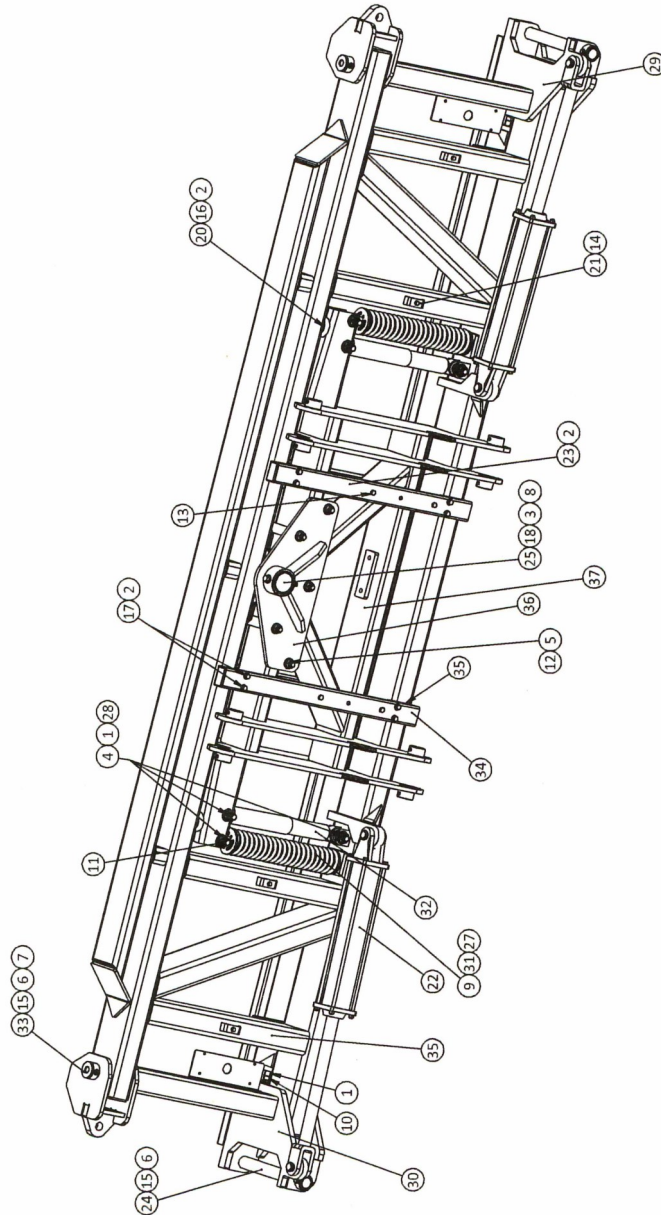

PARTS LIST		
No.	Part #	Qty. Part Description
1	5006093	6 3/4"-10 Hex Nut
2	5006259	14 3/8"-16nc Hex Flanged Whiz Nut Gr. 5
3	5006337	1 1/2"-13nc Hex Flanged Whiz Nut Gr. 5
4	5006359	6 3/4"-10nc Hex Flanged Toplock Nut Gr. 8
5	5006364	5 5/8"-11nc Hex Flanged Toplock Nut Gr. 8
6	5006367	6 5/16"-18nc Hex Flanged Toplock Nut Gr. 8
7	5012015	4 Grease Zerk, 1/4"-28 Thread
8	5012016	1 Grease Zerk, 1/8"-27 NPT Thread
9	5019258	2 Center Frame Spring
10	5034085	2 H.H.C.S. 3/4"-10nc X 2"
11	5034150	4 H.H.C.S. 3/4"-10nc X 4 1/2"
12	5034517	5 H.H.C.S. 5/8"-11 X 8"
13	5034546	4 H.H.C.S. 3/8"-16 X 10 1/2", Gr.8
14	5034613	4 H.H.C.S. Flanged 1/4"-20nc x 1 1/2"
15	5034642	6 H.H.C.S. Flanged 5/16"-18nc x 2 1/2"
16	5034663	2 H.H.C.S. Flanged 3/8"-16nc x 1 1/2"
17	5034668	8 H.H.C.S. Flanged 3/8"-16nc x 2 3/4"
18	5034704	1 H.H.C.S. Flanged 1/2"-13nc x 4 1/2"
19	5034755	2 Flng HH Bolt 3/4"-10 x 3 1/2"
20	5040019	2 Round Rubber Bumper
21	5051125	4 Hose Clamp
22	5061033	2 Hydraulic Cylinder, 3" x 16", 1.5" Rod
23	5100221	4 Spacer Tube
24	5101252	2 Pivot Pin (First Outer)
25	5101254	1 Center Pivot Pin
26	5121017	4 Shim (8650 Center Pivot)
27	5274717	2 Upper Slide Tube Weldment
28	5274718	2 Rod Eye Weldment
29	5274727	1 Hinge Tube Weldment (LH)
30	5274728	1 Hinge Tube Weldment (RH)
31	5274776	2 Lower Slide Tube Weldment
32	5274797	2 Shock Absorber
33	5274805	4 1 1/2" Dia. x 6 3/4" Hinge Pin Weldment
34	5275863	2 Upright Bolt-On Sandwich Tube Weldment (8650)
35	5275864	1 Center Frame Weldment (8650)
36	5275872	2 Narrow Sandwich Plate Weldment (8650)
37	5280701	1 Center Pivot Weldment (1350 - 1950)

# 5279133—7000 Series Lift Arms

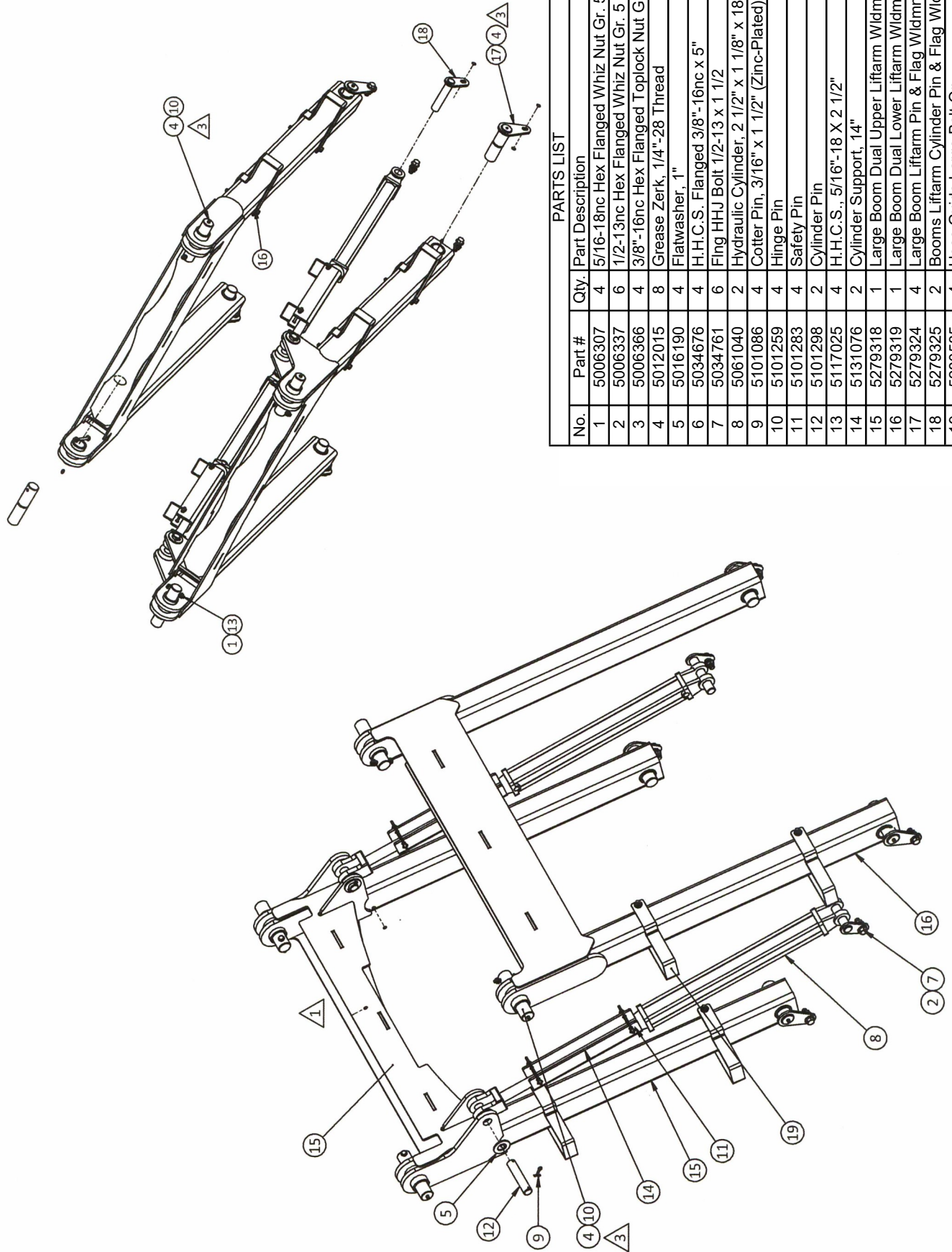

PARTS LIST			
No.	Part #	Qty.	Part Description
1	5006307	4	5/16-18nc Hex Flanged Whiz Nut Gr. 5
2	5006337	6	1/2-13nc Hex Flanged Whiz Nut Gr. 5
3	5006366	4	3/8"-16nc Hex Flanged Toplock Nut Gr. 8
4	5012015	8	Grease Zerk, 1/4"-28 Thread
5	5016190	4	Flatwasher, 1"
6	5034676	4	H.H.C.S. Flanged 3/8"-16nc x 5"
7	5034761	6	Fing HHJ Bolt 1/2-13 x 1 1/2
8	5061040	2	Hydraulic Cylinder, 2 1/2" x 1 1/8" x 18"
9	5101086	4	Cotter Pin, 3/16" x 1 1/2" (Zinc-Plated)
10	5101259	4	Hinge Pin
11	5101283	4	Safety Pin
12	5101298	2	Cylinder Pin
13	5117025	4	H.H.C.S., 5/16"-18 X 2 1/2"
14	5131076	2	Cylinder Support, 14"
15	5279318	1	Large Boom Dual Upper Liftarm Widmnt
16	5279319	1	Large Boom Dual Lower Liftarm Widmnt
17	5279324	4	Large Boom Liftarm Pin & Flag Widmnt
18	5279325	2	Booms Liftarm Cylinder Pin & Flag Widmnt
19	5280585	4	Hose Guide Large Bolt-On

### Hydraulic Tilt Cylinder Detail A

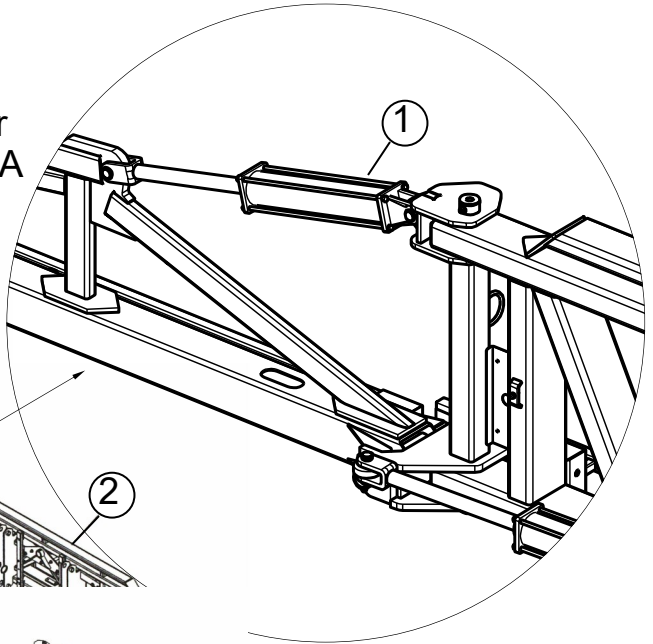

### 7000 Series—60' Boom

No.	Part #	Qty.	Part Description
1	5061033	2	Hydraulic Cylinder, 3" x 16", 1.5" Rod
2	5280841	1	7000 Series Boom Center Section Assembly
3	5301345	1	7000 Series Boom 60' Boom Wing (LH) Assembly
4	5301346	1	7000 Series Boom 60' Boom Wing (RH) Assembly

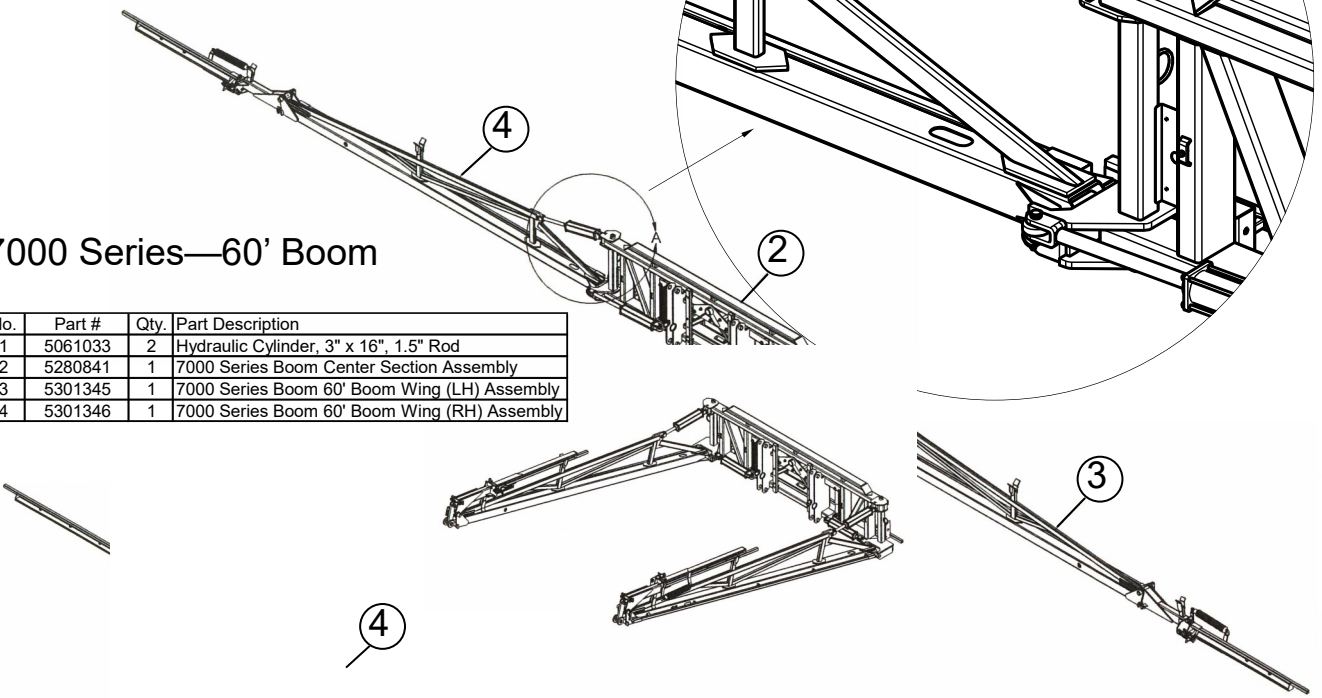

### 7000 Series—80' Boom

No.	Part #	Qty.	Part Description
1	5061033	2	Hydraulic Cylinder, 3" x 16", 1.5" Rod
2	5280841	1	7000 Series Boom Center Section Assembly
3	5301349	1	7000 Series Boom 80' Boom Wing (LH) Assembly
4	5301350	1	7000 Series Boom 80' Boom Wing (RH) Assembly

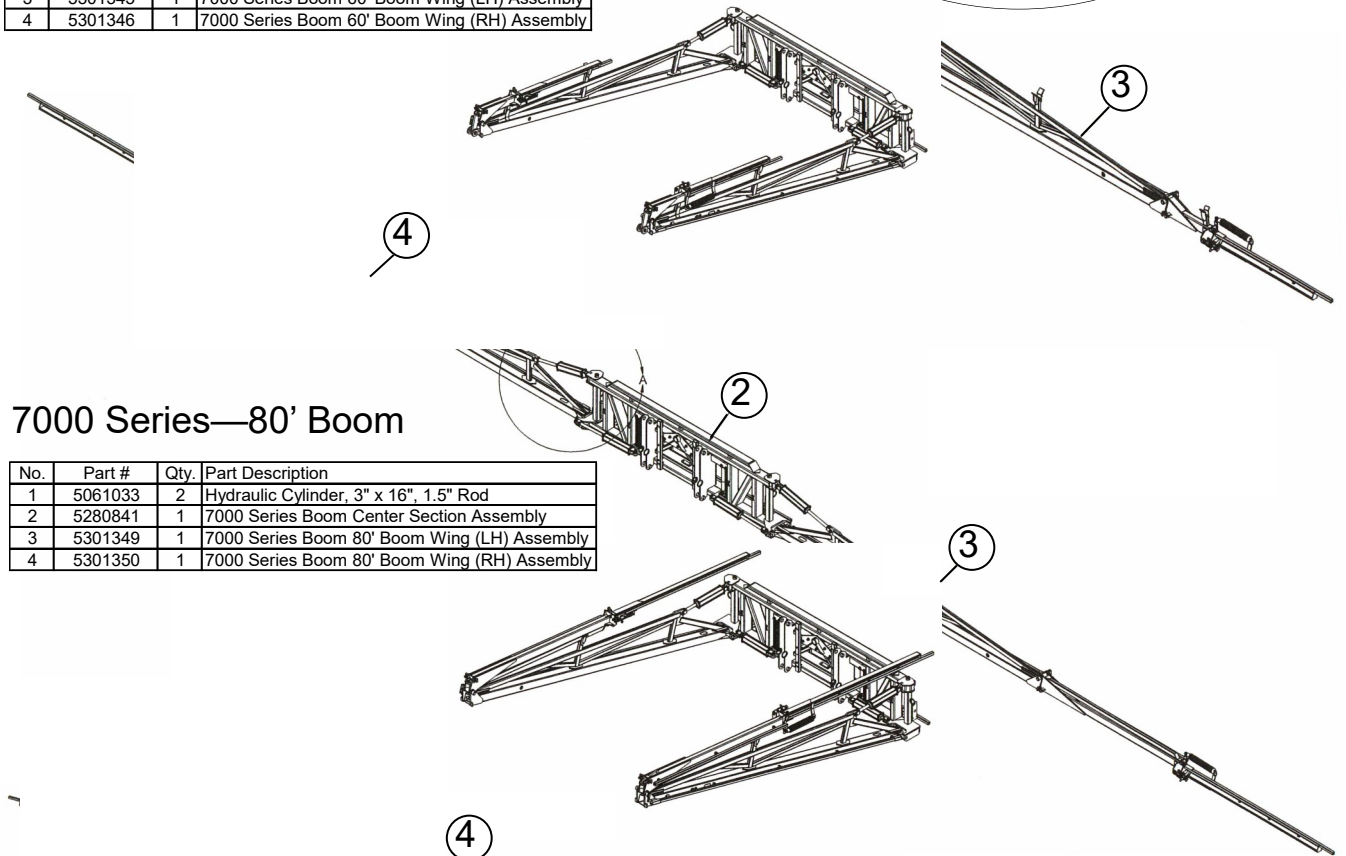

### 7000 Series—90' Boom

No.	Part #	Qty.	Part Description
1	5061033	2	Hydraulic Cylinder, 3" x 16", 1.5" Rod
2	5280841	1	7000 Series Boom Center Section Assembly
3	5301532	1	7000 Series Boom 90' Boom Wing (LH) Assembly
4	5301533	1	7000 Series Boom 90' Boom Wing (RH) Assembly

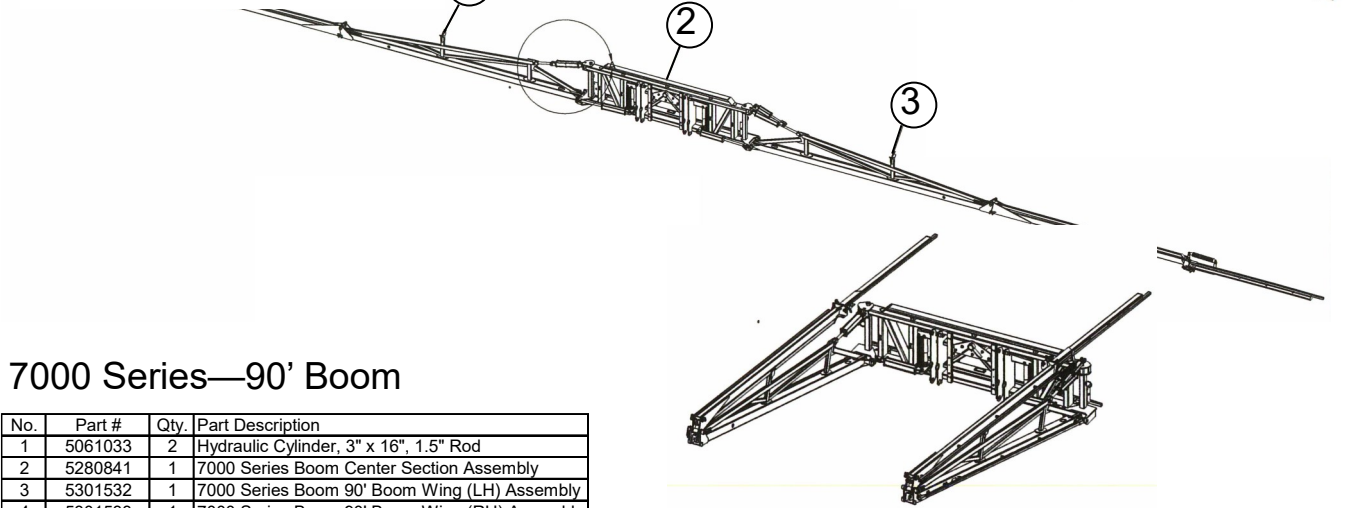

# 5301346—7000 Series 60' Wing Assembly (RH)

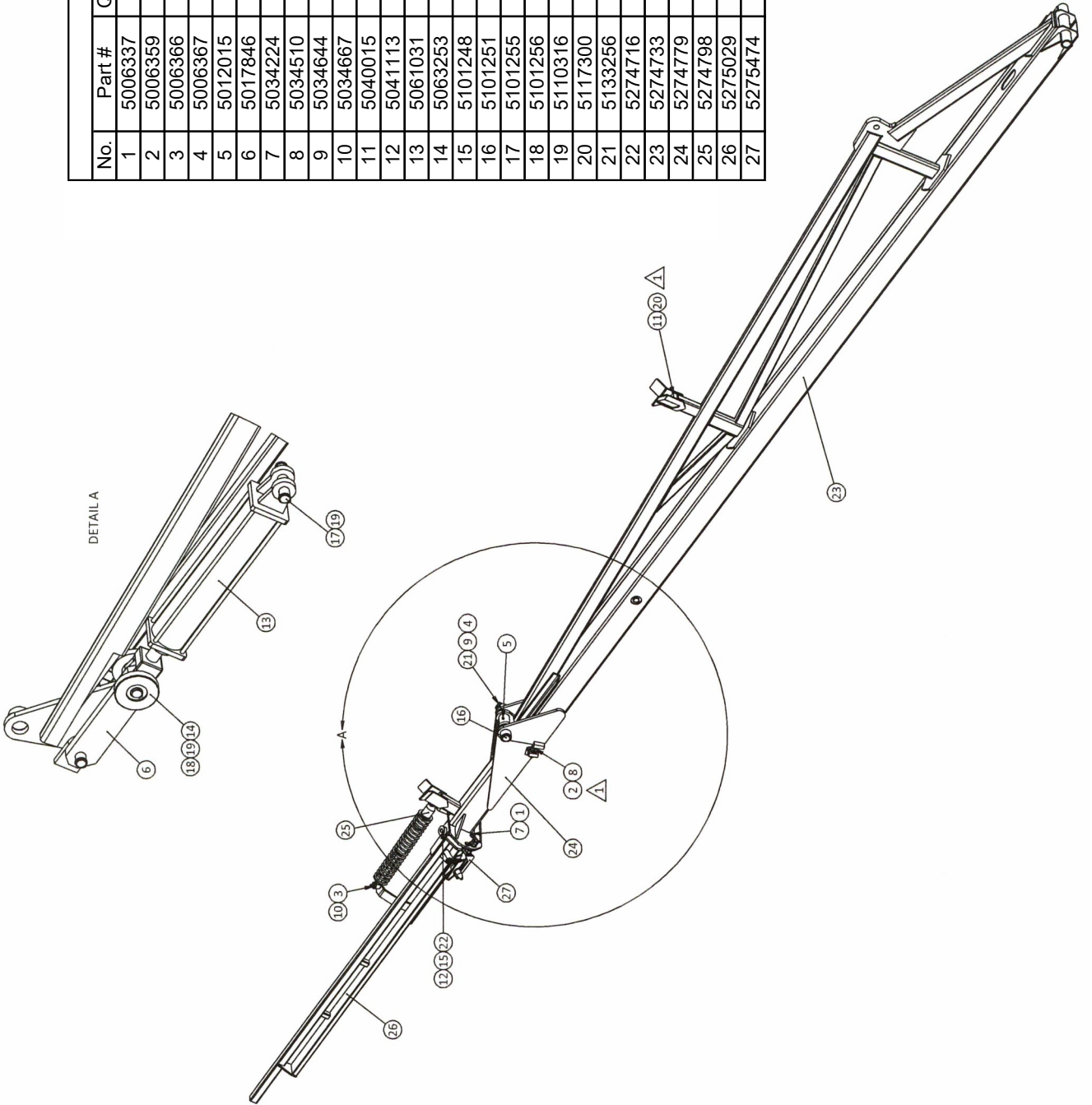

PARTS LIST			
No.	Part #	Qty.	Part Description
1	5006337	1	1/2-13nc Hex Flanged Whiz Nut Gr. 5
2	5006359	2	3/4-10nc Hex Flanged Toplock Nut Gr. 8
3	5006366	2	3/8"-16nc Hex Flanged Toplock Nut Gr. 8
4	5006367	1	5/16-18nc Hex Flanged Toplock Nut Gr. 8
5	5012015	3	Grease Zerk, 1/4"-28 Thread
6	5017846	1	Link Plate
7	5034224	1	H.H.C.S., 1/2"-13 x 3 1/4"
8	5034510	2	H.H.C.S., 3/4"-10nc x 2 1/2"
9	5034644	1	H.H.C.S. Flanged 5/16"-18nc x 3"
10	5034667	2	H.H.C.S. Flanged 3/8"-16nc x 2 1/2"
11	5040015	1	Bumper
12	5041113	1	Machinery Bushing, 1 1/2" O.D. x 1" I.D. x 10 Ga.
13	5061031	1	Hydraulic Cylinder, 3" x 16", 1.25" Rod
14	5063253	2	Glide Disc
15	5101248	1	Roll Pin, 1/4" Dia. x 1 1/2"
16	5101251	1	Pivot Pin (Second Outer)
17	5101255	1	Rear Cylinder Pin
18	5101256	1	Front Cylinder Pin
19	5110316	4	External Snap Ring
20	5117300	1	H.H.C.S. Flanged 5/16"-18nc x 1"
21	5133256	1	Hose Deflector Strap (Long)
22	5274716	1	Outer Boom Hinge Pin Weldment
23	5274733	1	Boom Weldment (RH) (First Outer)
24	5274779	1	Second Outer Boom Weldment (RH) (60')
25	5274798	1	Coil-Over Shock Absorber
26	5275029	1	Third Outer Boom Weldment (RH) (60')
27	5275474	1	Break-Away Pin Retainer Sub-Assembly



# 5301345—7000 Series 60' Wing Assembly (LH)

PARTS LIST			
No.	Part #	Qty.	Part Description
1	5006337	1	1/2-13nc Hex Flanged Whiz Nut Gr. 5
2	5006359	2	3/4-10nc Hex Flanged Toplock Nut Gr. 8
3	5006366	2	3/8"-16nc Hex Flanged Toplock Nut Gr. 8
4	5006367	1	5/16"-18nc Hex Flanged Toplock Nut Gr. 8
5	5012015	3	Grease Zerk, 1/4"-28 Thread
6	5017846	1	Link Plate
7	5034224	1	H.H.C.S., 1/2"-13 x 3 1/4"
8	5034510	2	H.H.C.S., 3/4"-10nc x 2 1/2"
9	5034644	1	H.H.C.S. Flanged 5/16"-18nc x 3"
10	5034667	2	H.H.C.S. Flanged 3/8"-16nc x 2 1/2"
11	5040015	1	Bumper
12	5041113	1	Machinery Bushing, 1 1/2" O.D. x 1" I.D. x 10 Ga.
13	5061031	1	Hydraulic Cylinder, 3" x 16", 1.25" Rod
14	5063253	2	Glide Disc
15	5101248	1	Roll Pin, 1/4" Dia. x 1 1/2"
16	5101251	1	Pivot Pin (Second Outer)
17	5101255	1	Rear Cylinder Pin
18	5101256	1	Front Cylinder Pin
19	5110316	4	External Snap Ring
20	5117300	1	H.H.C.S. Flanged 5/16"-18nc x 1"
21	5133256	1	Hose Deflector Strap (Long)
22	5274716	1	Outer Boom Hinge Pin Weldment
23	5274741	1	Boom Weldment (LH) (First Outer)
24	5274780	1	Second Outer Boom Weldment (LH) (60')
25	5274798	1	Coil-Over Shock Absorber
26	5275030	1	Third Outer Boom Weldment (LH) (60')
27	5275474	1	Break-Away Pin Retainer Sub-Assembly

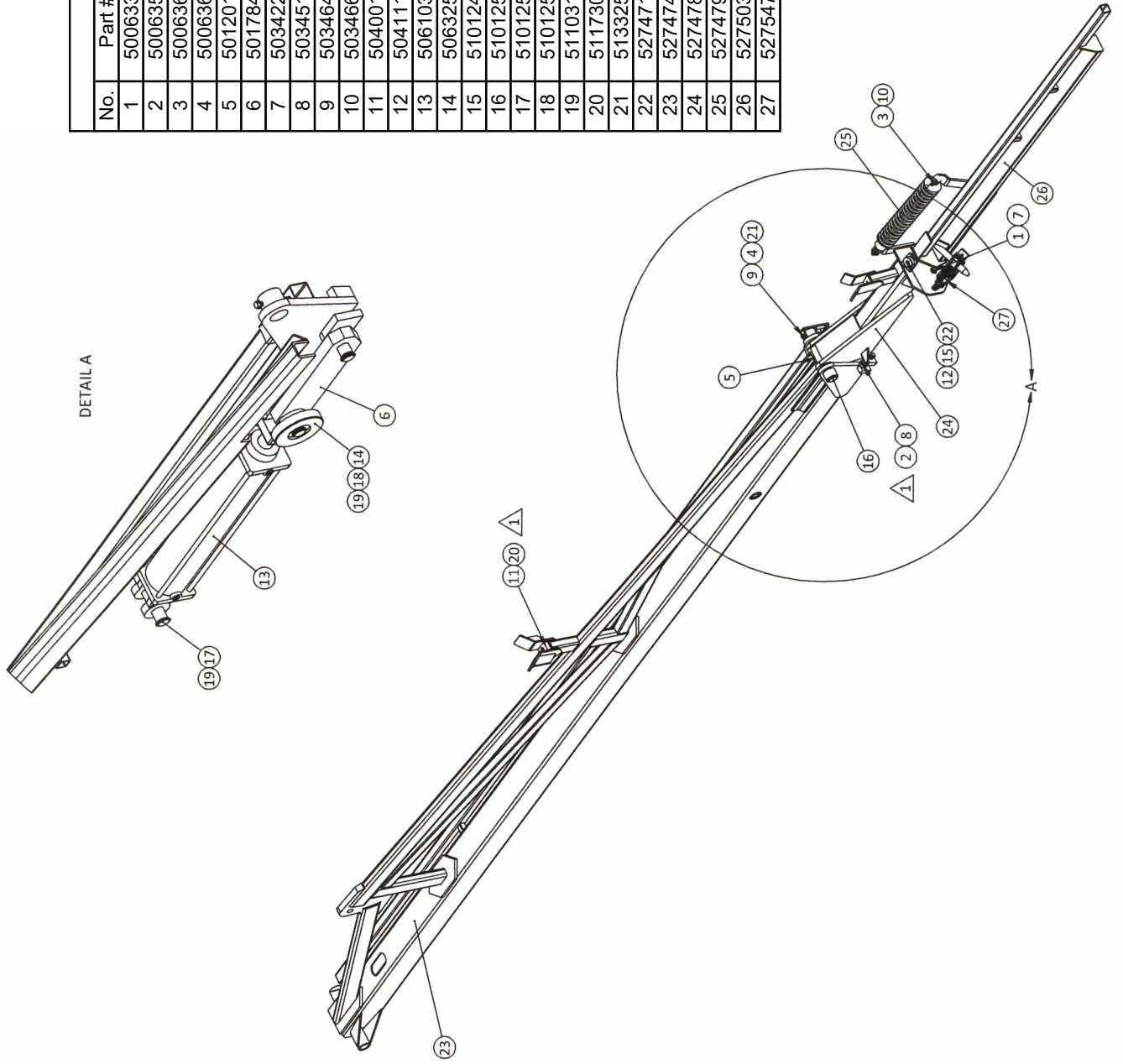



# 5301350—7000 Series 80' Wing Assembly (RH)

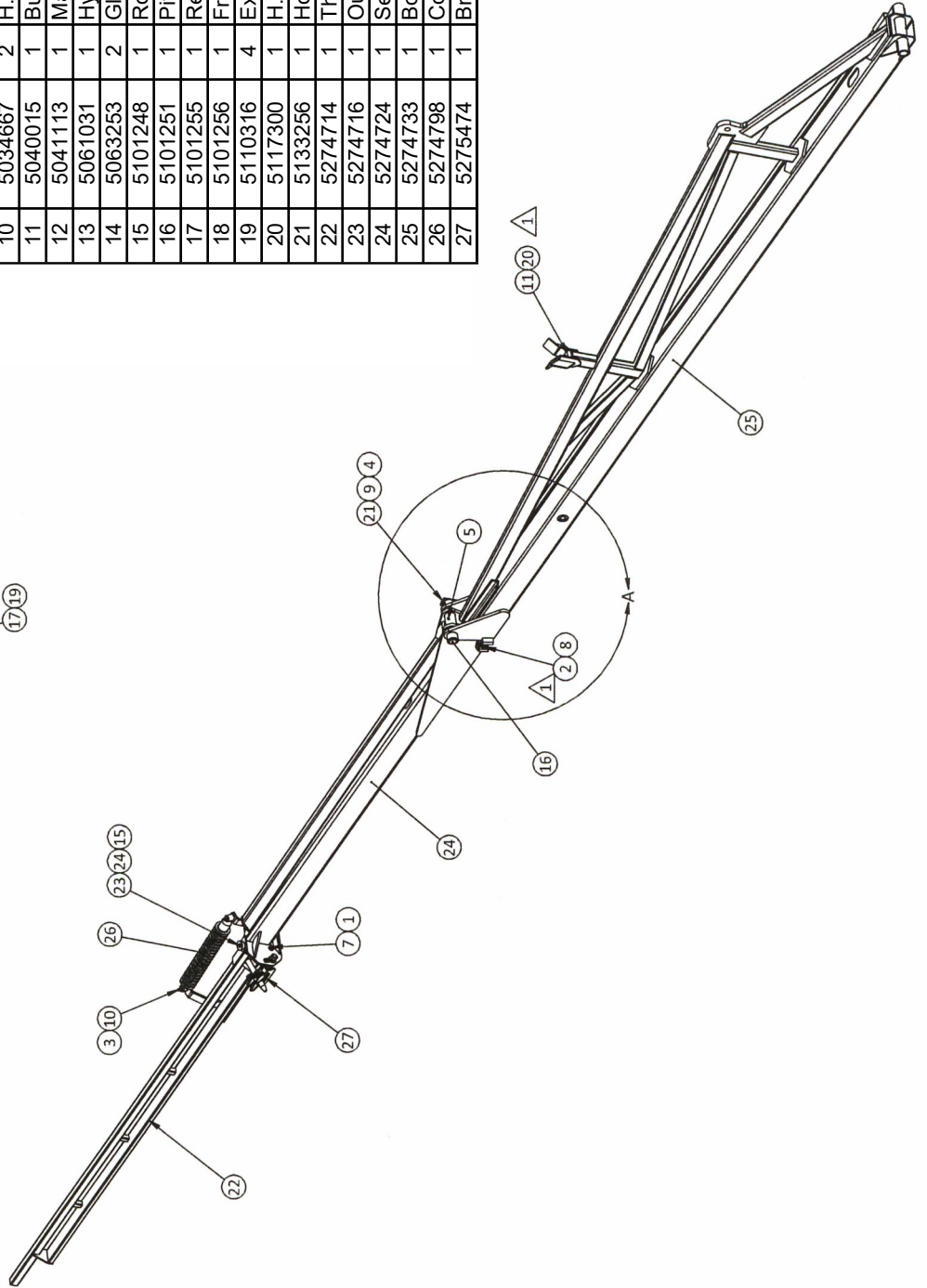
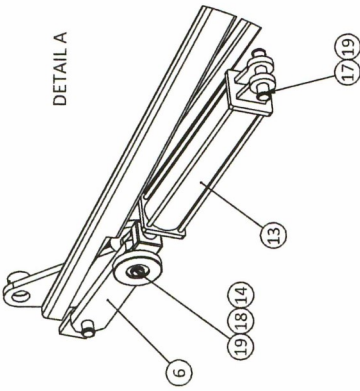

PARTS LIST		
No.	Part #	Qty. Part Description
1	5006337	1 1/2-13nc Hex Flanged Whiz Nut Gr. 5
2	5006359	2 3/4-10nc Hex Flanged Toplock Nut Gr. 8
3	5006366	2 3/8"-16nc Hex Flanged Toplock Nut Gr. 8
4	5006367	1 5/16-18nc Hex Flanged Toplock Nut Gr. 8
5	5012015	3 Grease Zerk, 1/4"-28 Thread
6	5017846	1 Link Plate
7	5034224	1 H.H.C.S., 1/2"-13 x 3 1/4"
8	5034510	2 H.H.C.S., 3/4"-10nc x 2 1/2"
9	5034644	1 H.H.C.S. Flanged 5/16"-18nc x 3"
10	5034667	2 H.H.C.S. Flanged 3/8"-16nc x 2 1/2"
11	5040015	1 Bumper
12	5041113	1 Machinery Bushing, 1 1/2" O.D. x 1" I.D. x 10 Ga.
13	5061031	1 Hydraulic Cylinder, 3" x 16", 1.25" Rod
14	5063253	2 Glide Disc
15	5101248	1 Roll Pin, 1/4" Dia. x 1 1/2"
16	5101251	1 Pivot Pin (Second Outer)
17	5101255	1 Rear Cylinder Pin
18	5101256	1 Front Cylinder Pin
19	5110316	4 External Snap Ring
20	5117300	1 H.H.C.S. Flanged 5/16"-18nc x 1"
21	5133256	1 Hose Deflector Strap (Long)
22	5274714	1 Third Outer Boom Weldment (RH) (80' & 90')
23	5274716	1 Outer Boom Hinge Pin Weldment
24	5274724	1 Second Outer Boom Weldment (RH) (80')
25	5274733	1 Boom Weldment (RH) (First Outer)
26	5274798	1 Coil-Over Shock Absorber
27	5275474	1 Break-Away Pin Retainer Sub-Assembly

# 5301349—7000 Series 80' Wing Assembly (LH)

PARTS LIST		
No.	Part #	Qty. Part Description
1	5006337	1 1/2-13nc Hex Flanged Whiz Nut Gr. 5
2	5006359	2 3/4-10nc Hex Flanged Toplock Nut Gr. 8
3	5006366	2 3/8"-16nc Hex Flanged Toplock Nut Gr. 8
4	5006367	1 5/16-18nc Hex Flanged Toplock Nut Gr. 8
5	5012015	3 Grease Zerk, 1/4"-28 Thread
6	5017846	1 Link Plate
7	5034224	1 H.H.C.S., 1/2"-13 x 3 1/4"
8	5034510	2 H.H.C.S., 3/4"-10nc x 2 1/2"
9	5034644	1 H.H.C.S., Flanged 5/16"-18nc x 3"
10	5034667	2 H.H.C.S., Flanged 3/8"-16nc x 2 1/2"
11	5040015	1 Bumper
12	5041113	1 Machinery Bushing, 1 1/2" O.D. x 1" I.D. x 10 Ga.
13	5061031	1 Hydraulic Cylinder, 3" x 16", 1.25" Rod
14	5063253	2 Glide Disc
15	5101248	1 Roll Pin, 1/4" Dia. x 1 1/2"
16	5101251	1 Pivot Pin (Second Outer)
17	5101255	1 Rear Cylinder Pin
18	5101256	1 Front Cylinder Pin
19	5110316	4 External Snap Ring
20	5117300	1 H.H.C.S., Flanged 5/16"-18nc x 1"
21	5133256	1 Hose Deflector Strap (Long)
22	5274716	1 Outer Boom Hnge Pin Weldment
23	5274741	1 Boom Weldment (LH) (First Outer)
24	5274767	1 Third Outer Boom Weldment (LH) (80' & 90')
25	5274774	1 Second Outer Boom Weldment (LH) (80')
26	5274798	1 Coil-Over Shock Absorber
27	5275474	1 Break-Away Pin Retainer Sub-Assembly

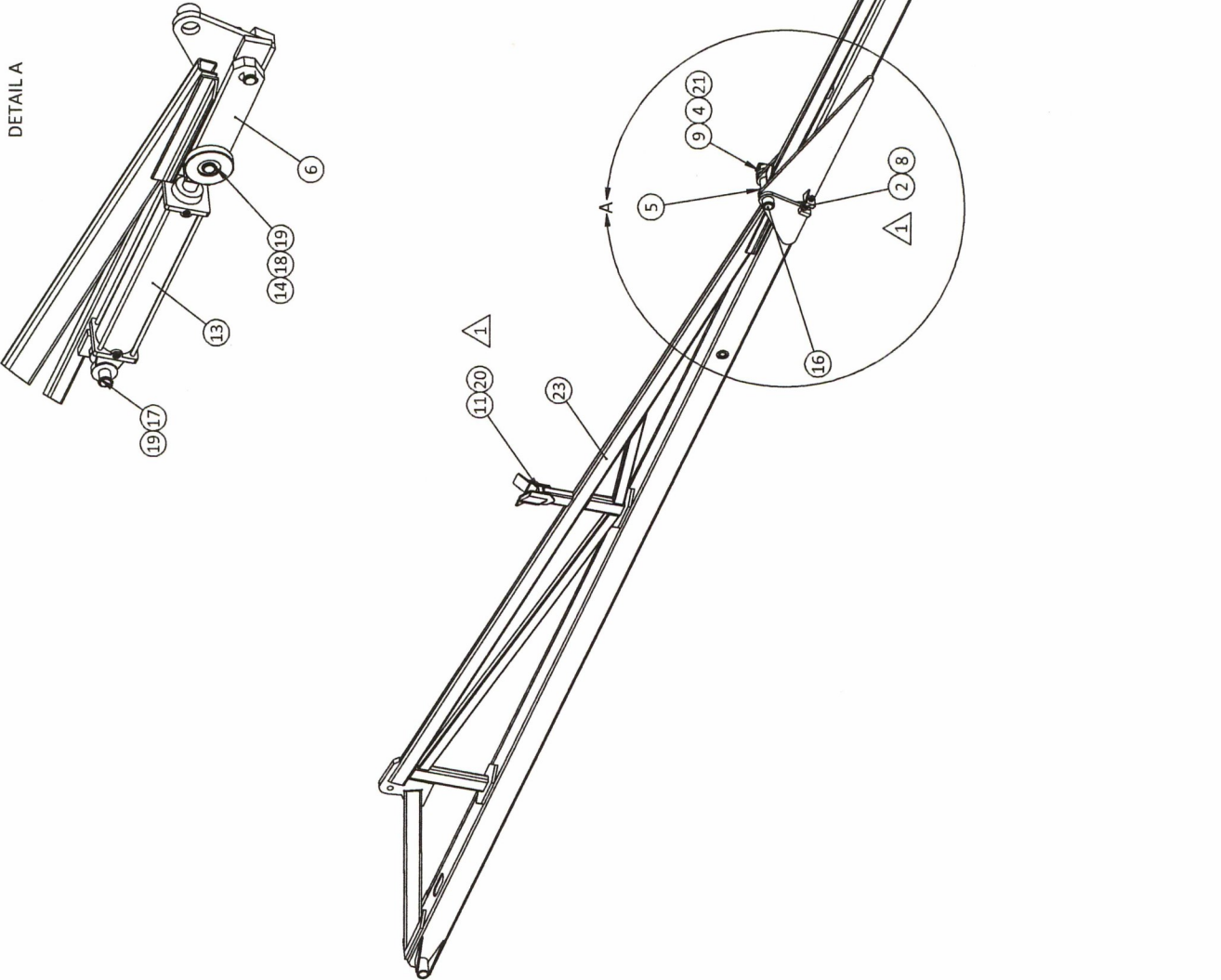

# 5301533—7000 Series 90' Wing Assembly (RH)

PARTS LIST		
No.	Part #	Qty. Part Description
1	5006337	1 1/2-13nc Hex Flanged Whiz Nut Gr. 5
2	5006359	2 3/4-10nc Hex Flanged Toplock Nut Gr. 8
3	5006366	2 3/8"-16nc Hex Flanged Toplock Nut Gr. 8
4	5006367	1 5/16-18nc Hex Flanged Toplock Nut Gr. 8
5	5012015	3 Grease Zerk, 1/4"-28 Thread
6	5017846	1 Link Plate
7	5034224	1 H.H.C.S., 1/2"-13 x 3 1/4"
8	5034510	2 H.H.C.S., 3/4"-10nc x 2 1/2"
9	5034644	2 H.H.C.S. Flanged 5/16"-18nc x 3"
10	5034667	2 H.H.C.S. Flanged 3/8"-16nc x 2 1/2"
11	5040015	1 Bumper
12	5041113	1 Machinery Bushing, 1 1/2" O.D. x 1" I.D. x 10 Ga.
13	5061031	1 Hydraulic Cylinder, 3" x 16", 1.25" Rod
14	5063253	2 Glide Disc
15	5101248	1 Roll Pin, 1/4" Dia. x 1 1/2"
16	5101251	1 Pivot Pin (Second Outer)
17	5101255	1 Rear Cylinder Pin
18	5101256	1 Front Cylinder Pin
19	5110316	4 External Snap Ring
20	5117300	1 H.H.C.S. Flanged 5/16"-18nc x 1"
21	5133256	1 Hose Deflector Strap (Long)
22	5274714	1 Third Outer Boom Weldment (RH) (80' & 90')
23	5274716	1 Outer Boom Hinge Pin Weldment
24	5274733	1 Boom Weldment (RH) (First Outer)
25	5274777	1 Second Outer Boom Weldment (RH) (90')
26	5274798	1 Coil-Over Shock Absorber
27	5275474	1 Break-Away Pin Retainer Sub-Assembly

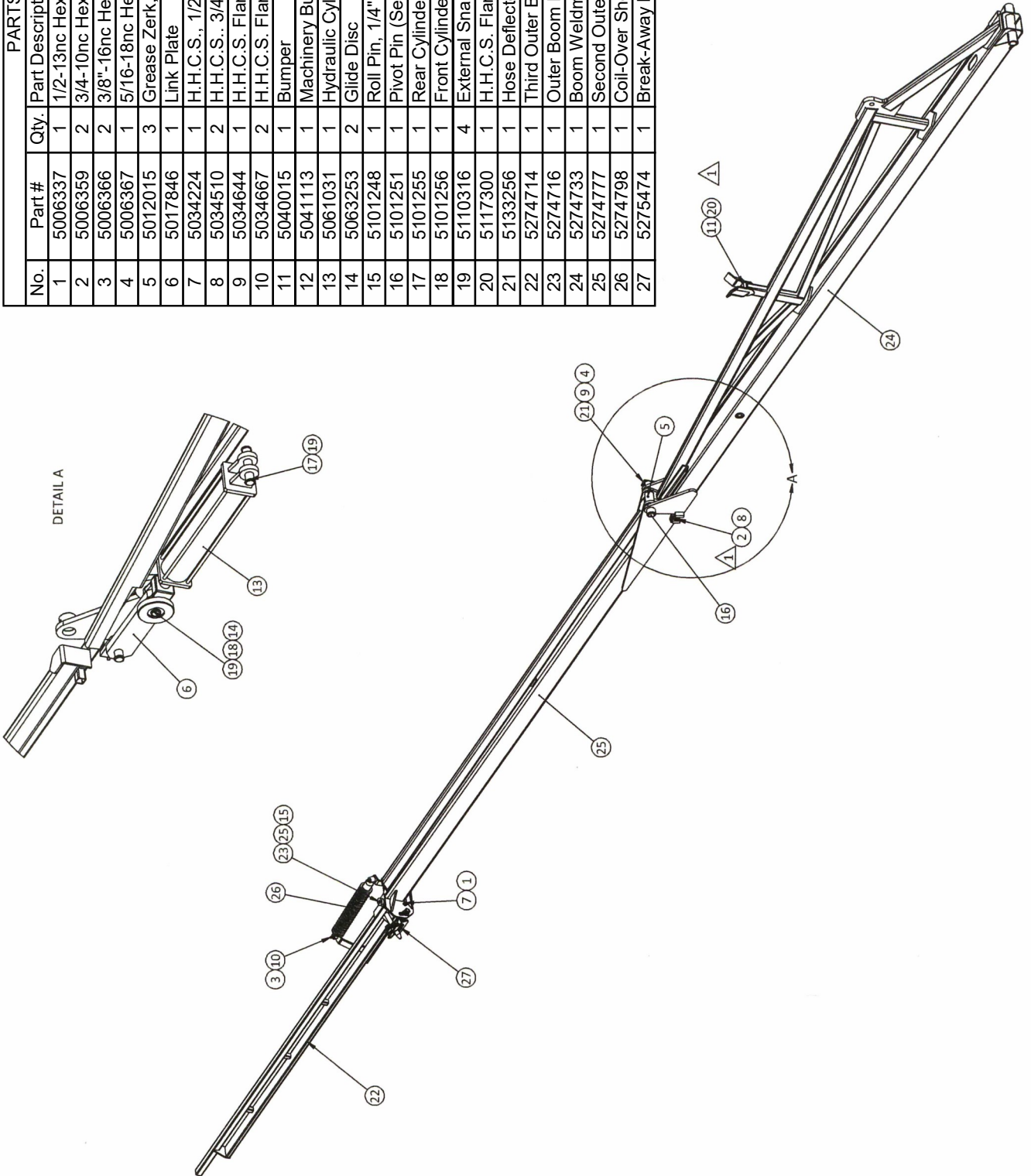

# 5301532—7000 Series 90' Wing Assembly (LH)

PARTS LIST		
No.	Part #	Qty. Part Description
1	5006337	1 1/2-13nc Hex Flanged Whiz Nut Gr. 5
2	5006359	2 3/4-10nc Hex Flanged Toplock Nut Gr. 8
3	5006366	2 3/8"-16nc Hex Flanged Toplock Nut Gr. 8
4	5006367	1 5/16-18nc Hex Flanged Toplock Nut Gr. 8
5	5012015	3 Grease Zerk, 1/4"-28 Thread
6	5017846	1 Link Plate
7	5034224	1 H.H.C.S., 1/2"-13 x 3 1/4"
8	5034510	2 H.H.C.S., 3/4"-10nc x 2 1/2"
9	5034644	1 H.H.C.S. Flanged 5/16"-18nc x 3"
10	5034667	2 H.H.C.S. Flanged 3/8"-16nc x 2 1/2"
11	5040015	1 Bumper
12	5041113	1 Machinery Bushing, 1 1/2" O.D. x 1" I.D. x 10 Ga.
13	5061031	1 Hydraulic Cylinder, 3" x 16", 1.25" Rod
14	5063253	2 Glide Disc
15	5101248	1 Roll Pin, 1/4" Dia. x 1 1/2"
16	5101251	1 Pivot Pin (Second Outer)
17	5101255	1 Rear Cylinder Pin
18	5101256	1 Front Cylinder Pin
19	5110316	4 External Snap Ring
20	5117300	1 H.H.C.S. Flanged 5/16"-18nc x 1"
21	5274716	1 Outer Boom Hinge Pin Weldment
22	5133256	1 Hose Deflector Strap (Long)
23	5274741	1 Boom Weldment (LH) (First Outer)
24	5274767	1 Third Outer Boom Weldment (LH) (80' & 90')
25	5274778	1 Second Outer Boom Weldment (LH) (90')
26	5274798	1 Coil-Over Shock Absorber
27	5275474	1 Break-Away Pin Retainer Sub-Assembly

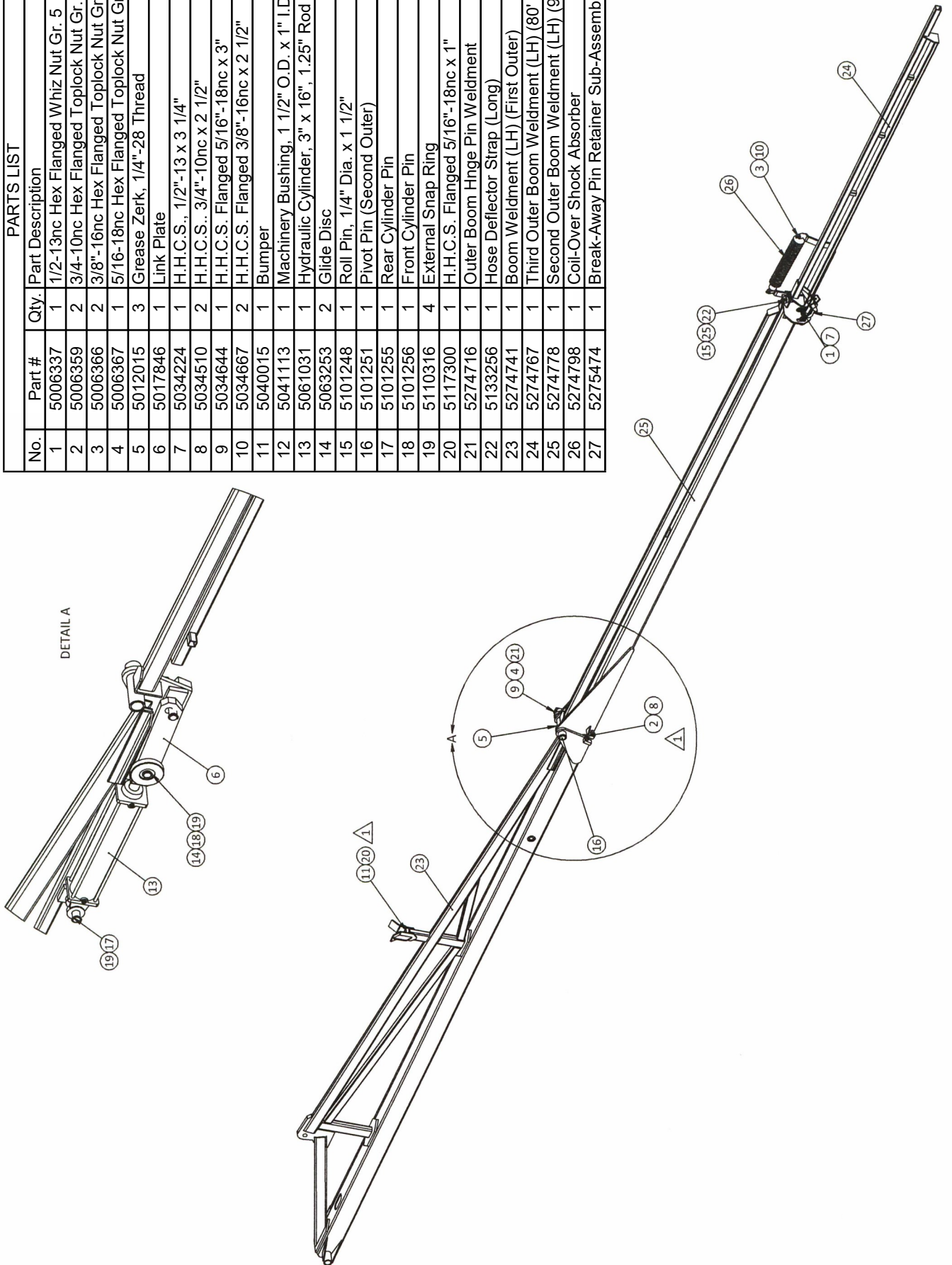



## 5280856 - Short Adjustable 15K Axle with IF320/90R46 Tires

Item No	Part Number	Qty.
1	5280851	1
2	5280852	1
3	5280853	1

Adjustable Width to:

60"

72"

80"

88"

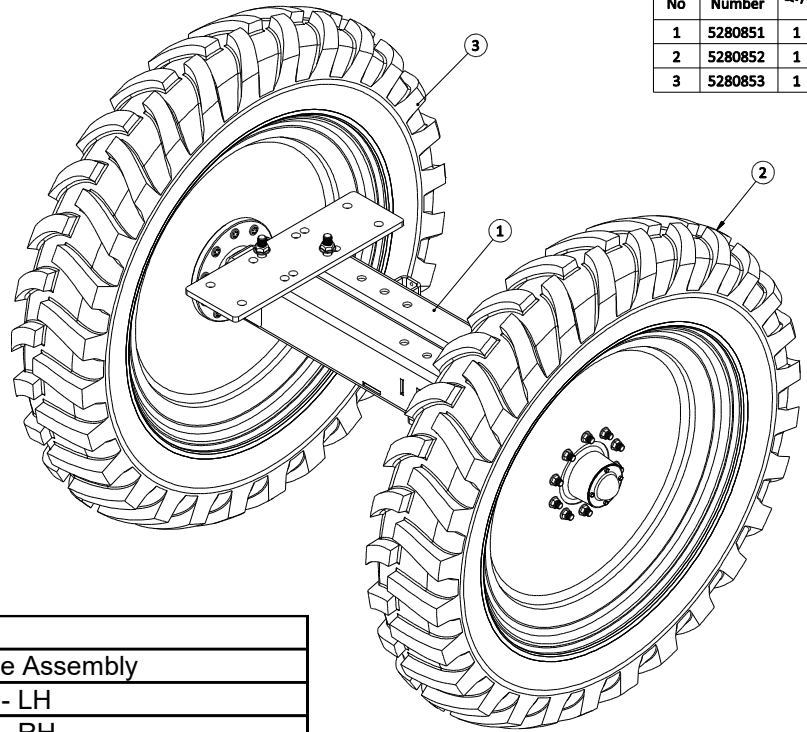

No.	Part #	Qty.	Part Description
1	5280851	1	15K Short Adjustable Axle Assembly
2	5280852	1	Tire & Rim IF320/90R46 - LH
3	5280853	1	Tire & Rim IF320/90R46 - RH

## 5280859 - Long Adjustable 15K Axle with IF320/90R46 Tires

No.	Part #	Qty.	Part Description
1	5280849	1	15K Long Adjustable Axle Assembly
2	5280852	1	Tire & Rim IF320/90R46 - LH
3	5280853	1	Tire & Rim IF320/90R46 - RH

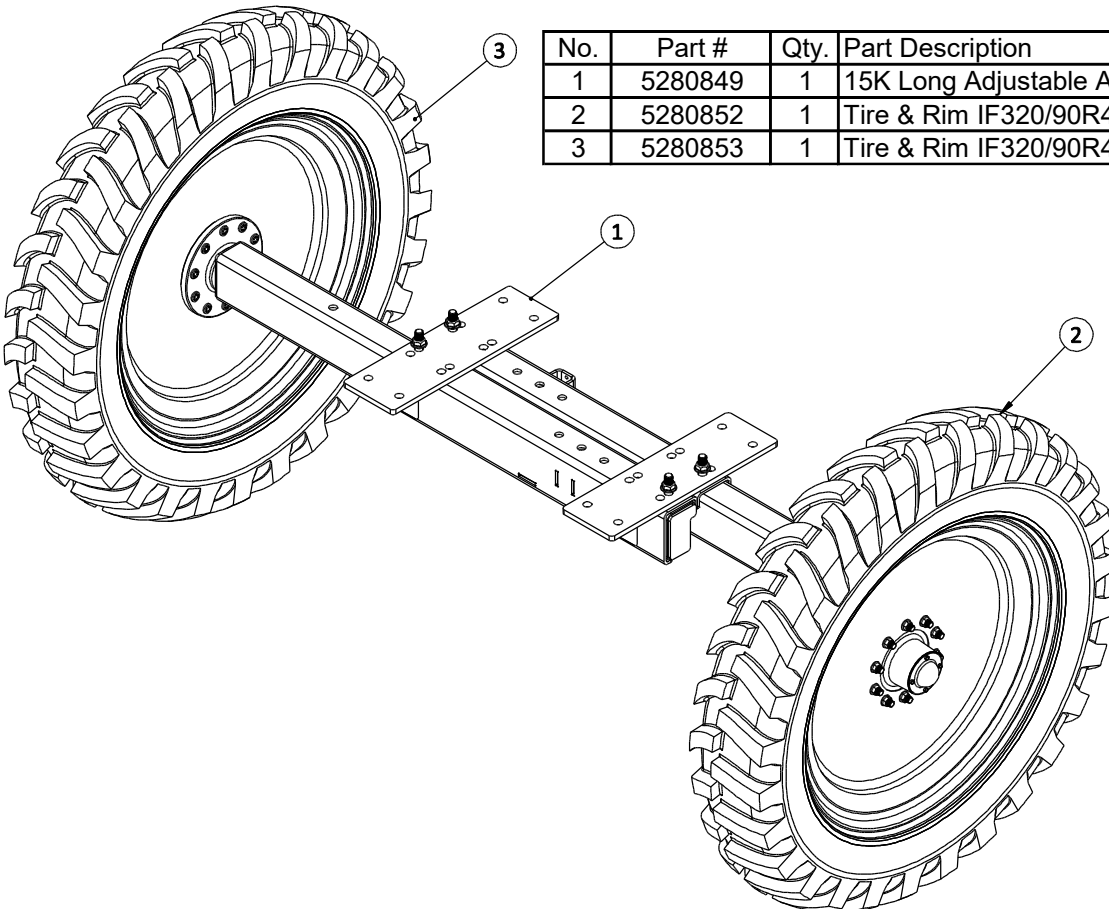

## 5280857 - Short Adjustable 15K Axle with IF380/90R46 Tires

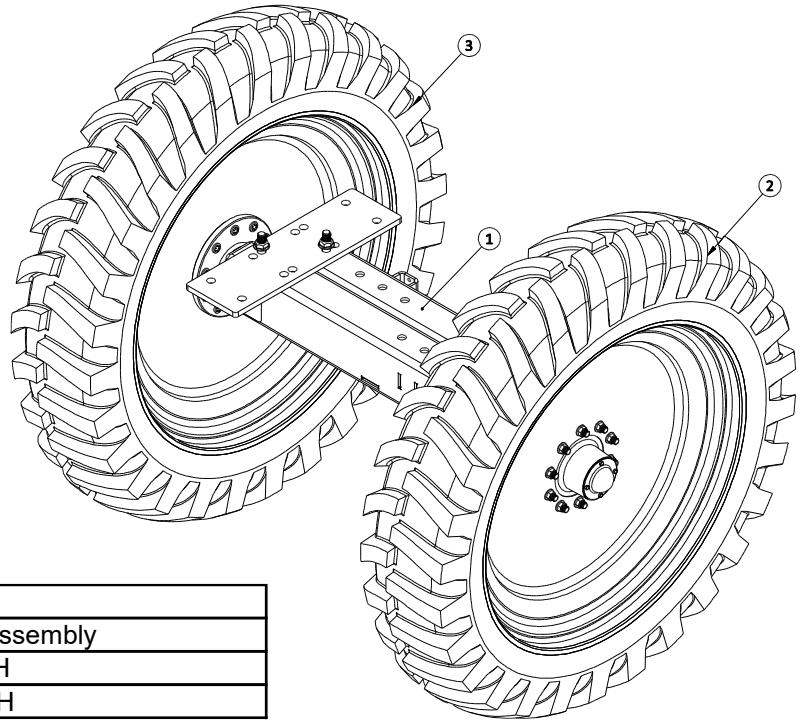

No.	Part #	Qty.	Part Description
1	5280851	1	15K Short Adjustable Axle Assembly
2	5280854	1	Tire & Rim IF380/90R46 - LH
3	5280855	1	Tire & Rim IF380/90R46 - RH

## 5280858 - Long Adjustable 15K Axle with IF380/90R46 Tires

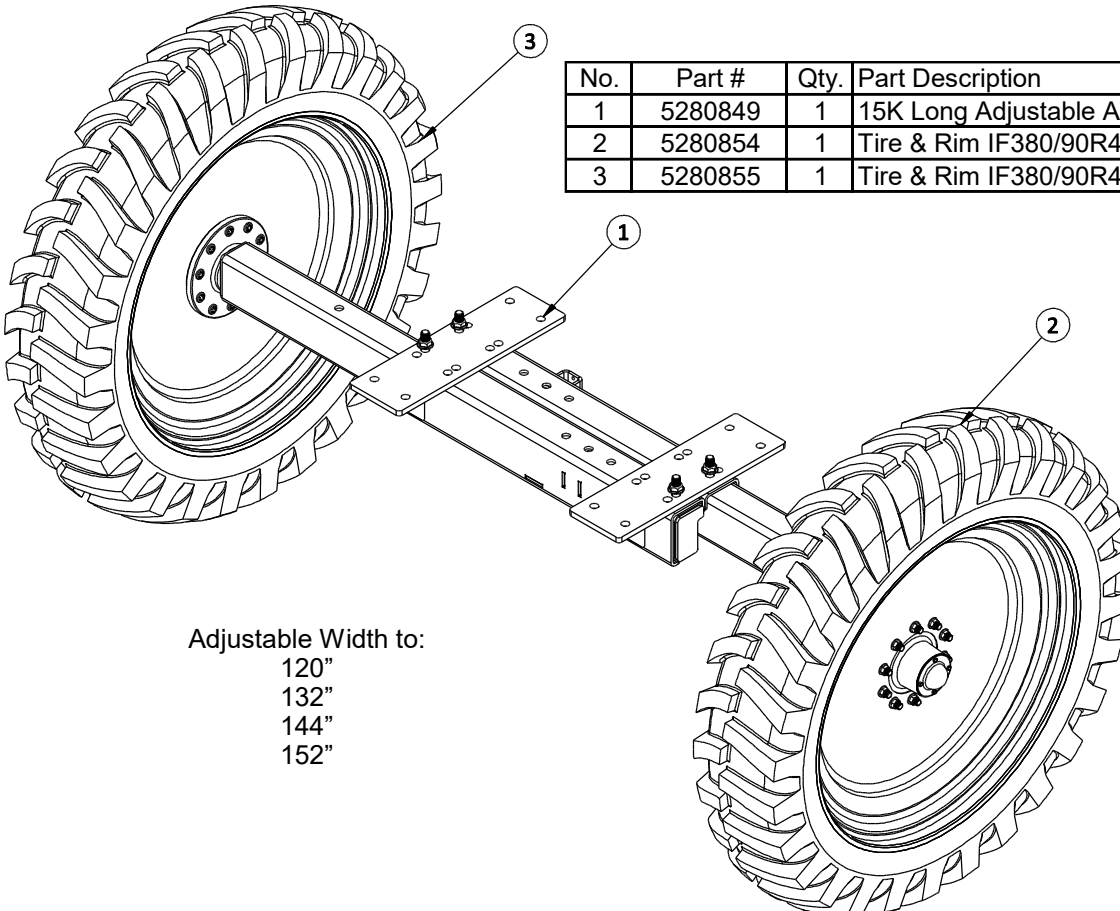

No.	Part #	Qty.	Part Description
1	5280849	1	15K Long Adjustable Axle Assembly
2	5280854	1	Tire & Rim IF380/90R46 - LH
3	5280855	1	Tire & Rim IF380/90R46 - RH

Adjustable Width to:  
 120"  
 132"  
 144"  
 152"

## 5280846 - Dual Axle, 60" - 120", IF320/90R46 Tires

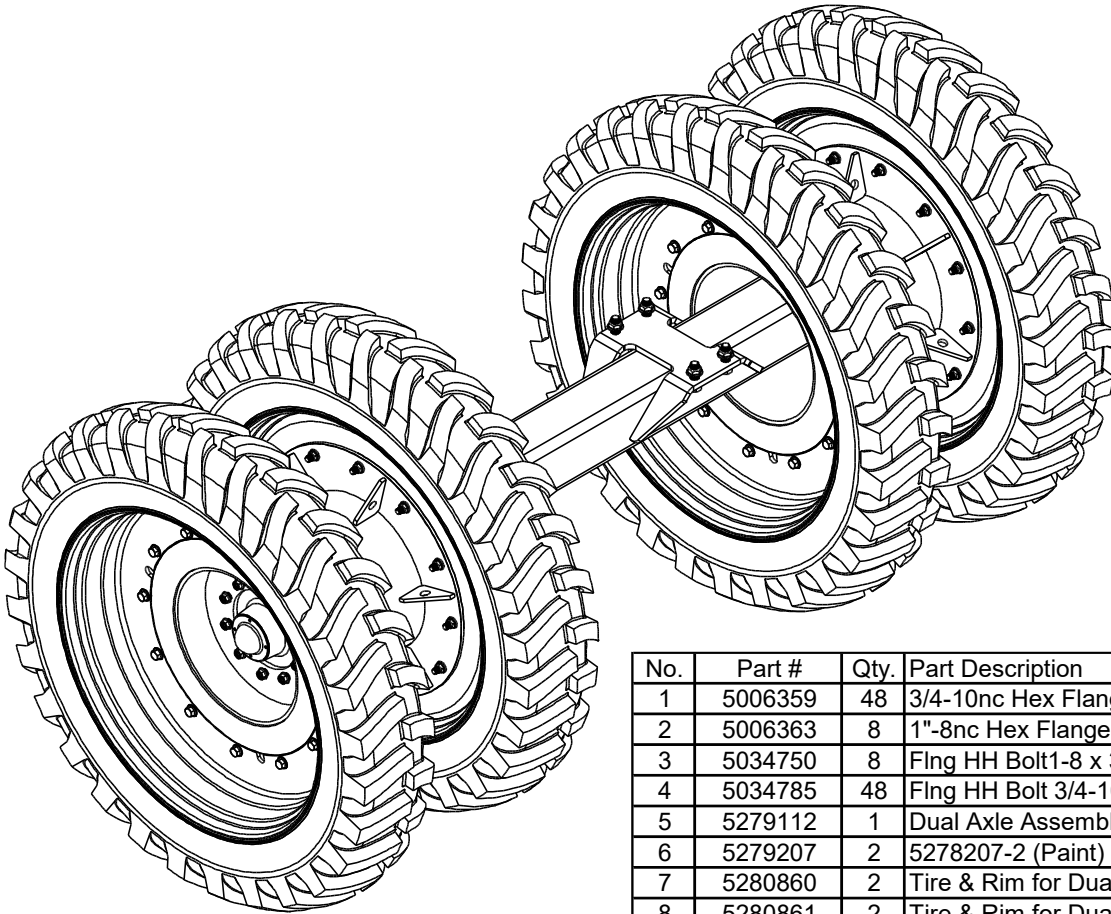

No.	Part #	Qty.	Part Description
1	5006359	48	3/4"-10nc Hex Flanged Toplock Nut Gr. 8
2	5006363	8	1"-8nc Hex Flanged Toplock Nut Gr. 8
3	5034750	8	Flng HH Bolt1-8 x 3"
4	5034785	48	Flng HH Bolt 3/4"-10 x 2 1/2"
5	5279112	1	Dual Axle Assembly
6	5279207	2	5278207-2 (Paint)
7	5280860	2	Tire & Rim for Dual IF380/90R46 - LH
8	5280861	2	Tire & Rim for Dual IF380/90R46 - RH

## 5275474 - Break Away Clasp

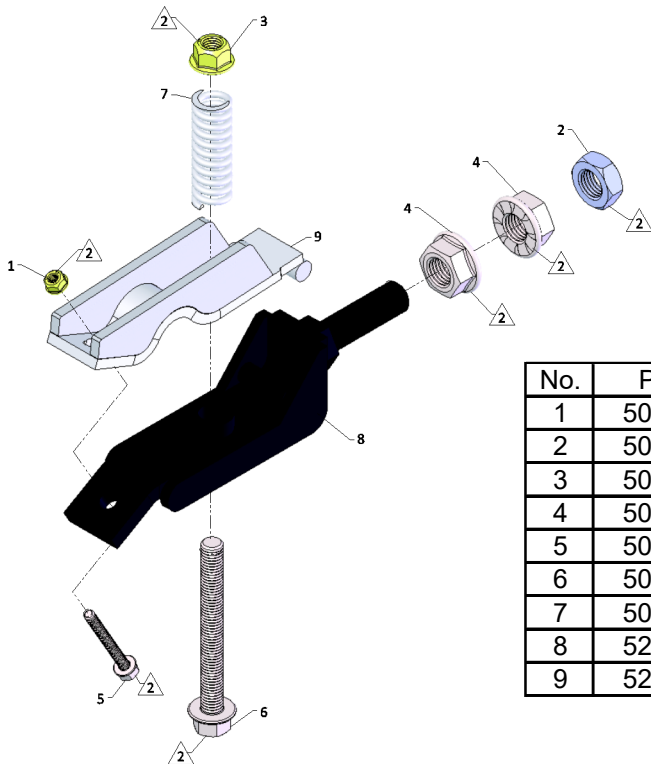

No.	Part #	Qty.	Part Description
1	5006344	1	1/4"-20nc Hex Flanged Toplock Nut Gr. 5
2	5006260	1	3/4"-10 Hex Jam Nut
3	5006365	1	1/2"-13nc Hex Flanged Toplock Nut Gr. 8
4	5006369	2	3/4"-10nc Hex Flanged Whiz Nut Gr. 5
5	5034616	1	H.H.C.S. Flanged 1/4"-20nc x 2 1/4"
6	5034704	1	H.H.C.S. Flanged 1/2"-13nc x 4 1/2"
7	5019257	1	Spring
8	5274711	1	Break-Away Pin Lower Retainer Wldmnt
9	5274712	1	Break-Away Pin Upper Retainer Wldmnt

# 3376-1670 - Hypro Cleanload

**CAUTION:**  
Only Use Genuine Hypro  
Replacement Parts

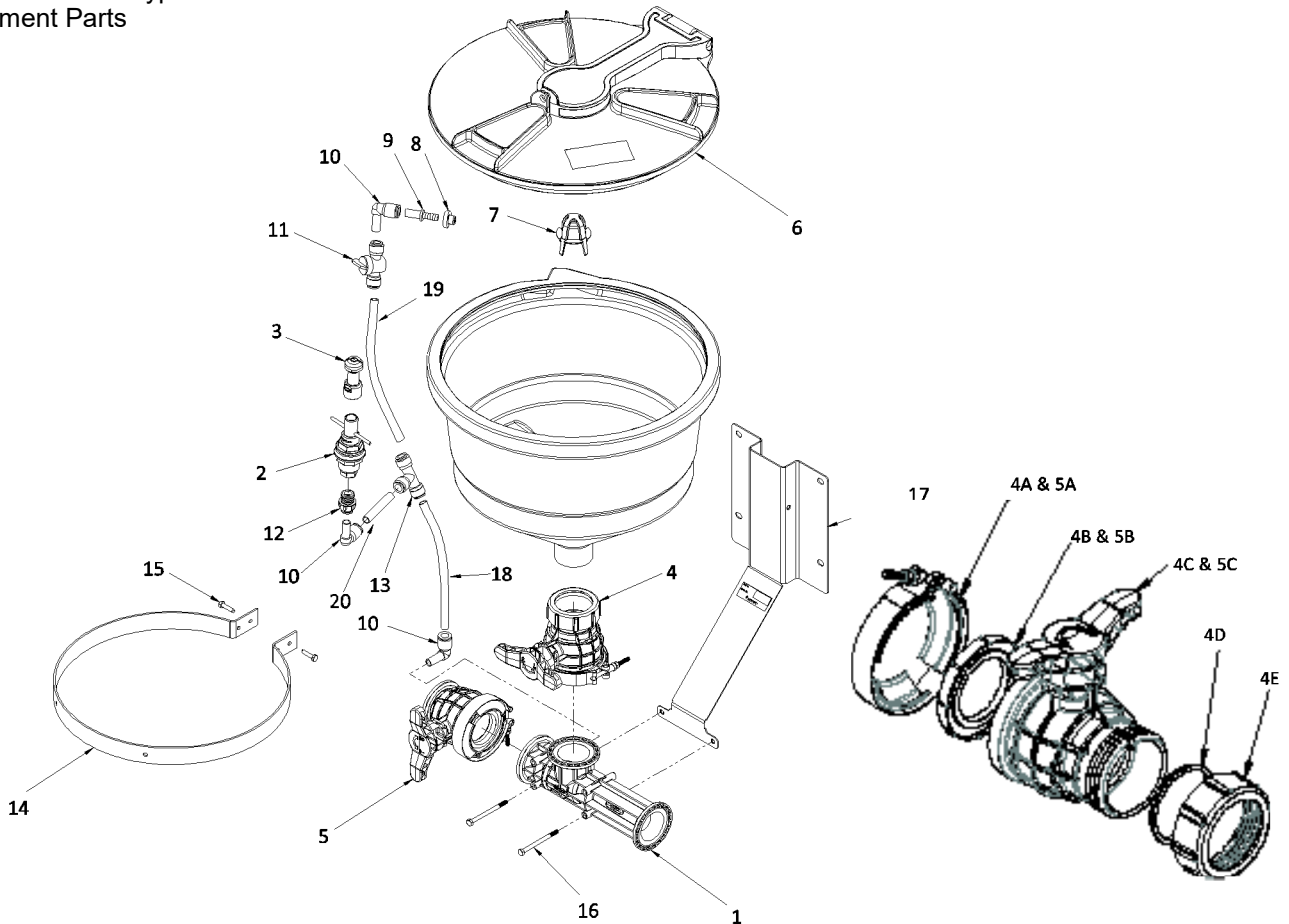

**NOTE:** When ordering parts, give quantity, part number, description and complete model number. Reference numbers are used ONLY to identify parts in the drawing and are NOT to be used as order numbers.

Tube Kit No. 3430-0833  
Contains: Tubing (Ref. 18) (Ref. 19) (Ref. 20),  
one screw (not shown), & one hose clamp (not shown)

Ref. No.	Qty. Req'd.	Part #	Description
1	1	3371-0036R	Eductor (for Model 3376-0870)
1	1	3371-0037R	Eductor (for Model 3376-0871)
1	1	3371-0038R	Eductor (for Model 3376-1170)
1	1	3371-0039R	Eductor (for Model 3376-1171)
1	1	3371-0040R	Eductor (for Model 3376-1670)
1	1	3371-0041R	Eductor (for Model 3376-1671)
2	1	PV1/2F1/2M-MA	ProClean Container Rinse
3	1	PC1/2F-36075	Nozzle, ProClean Container Rinse
4	1	7250-5000	Tank Valve
4A	1	7550-5028	Valve Clamp
4B	1	1700-0259	Gasket
4C	1	2800-003 1	Handle Red
4D	1	1700-0254	Gasket
4E	1	3240-0009	Nut
5	1	7250-5002	UF Valve
5A	1	7550-5028	Valve Clamp
5B	1	1700-0254	Gasket
5C	1	2800-0030	Handle Yellow

Ref. No.	Qty. Req'd.	Part #	Description
6	1	TL16-0006	Lid Kit
7	1	3350-0180	Strainer
8	1	1700-0253	Grommet
9	1	2404-0413	Hose Barb Fitting
10	3	2404-0414	Elbow Fitting (1/2")
11	1	3305-0113	Two-Way Valve (1/2")
12	1	2404-0386	Fitting
13	1	2404-0415	Tee Fitting (1/2")
14	1	1510-0128	Mounting Ring
15	2	2210-0201	Hex Bolt, M6x1x25
16	2	2210-0200	Hex Bolt M6x1x80
17	1	1510-0127	Bracket
18	1	3430-0833	Tube Kit
19	1	3430-0833	Tube Kit
20	1	3430-0833	Tube Kit



# 5085055 - Hub Assembly

No.	Part #	Qty.	Part Description
1	5085055a	1	Hub w/Cups
2	5046365	1	Hub Cap w/Gasket & Bolts
3	5031153	1	Inner Cone Bearing
4	5031154	1	Outer Cone Bearing
5	5085055c	1	Grease Seal
6	5006330	10	Wheel Nut (3/4"-16 UNF)
7	5085055b	10	Stud Bolt (3/4"-16 UNF x ____")

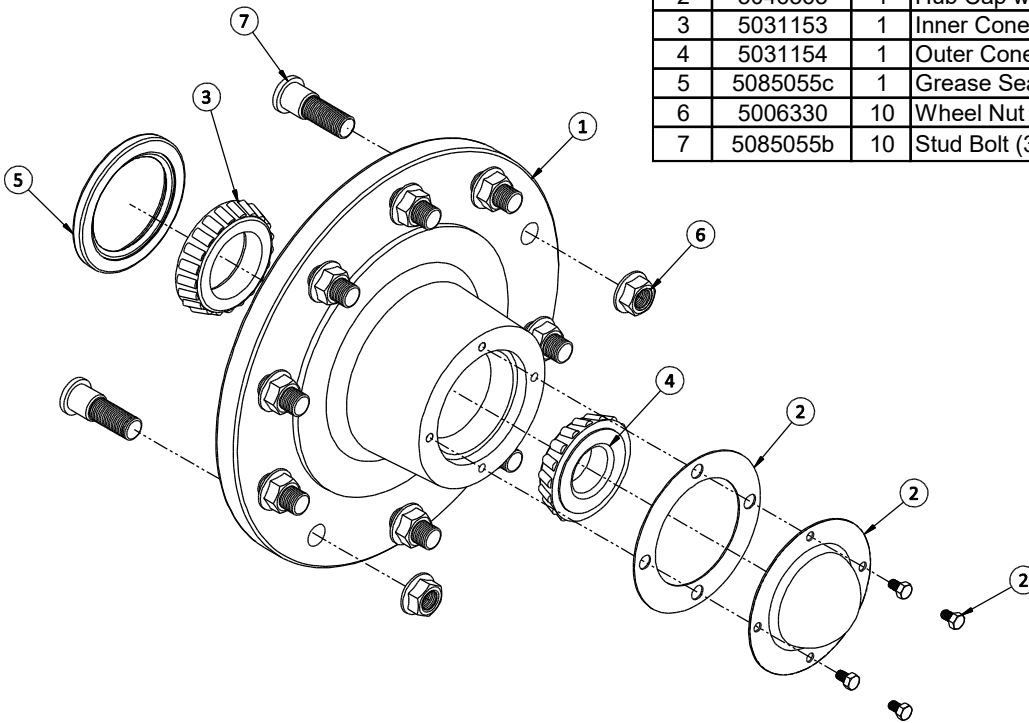

# RFM 60 P Flowmeter Replacement Parts 063-0171-793

No.	Raven Part #	Part Description
1	106-0159-514	Body, RFM 60 P Flowmeter
2	063-0171-673	Rotor/Magnet Assembly
3	063-0171-674	Hub/Bearing Assembly, Upstream
4	063-0171-769	Hub Assembly, Downstream
5	335-0000-278	Ring, Retaining, Internal
6	063-0173-062	Stud Bearing
7	435-3002-017	Clamp, Cable
8	310-0002-137	Screw, Thread Forming
9	063-0171-669	Sensor, Assembly, External

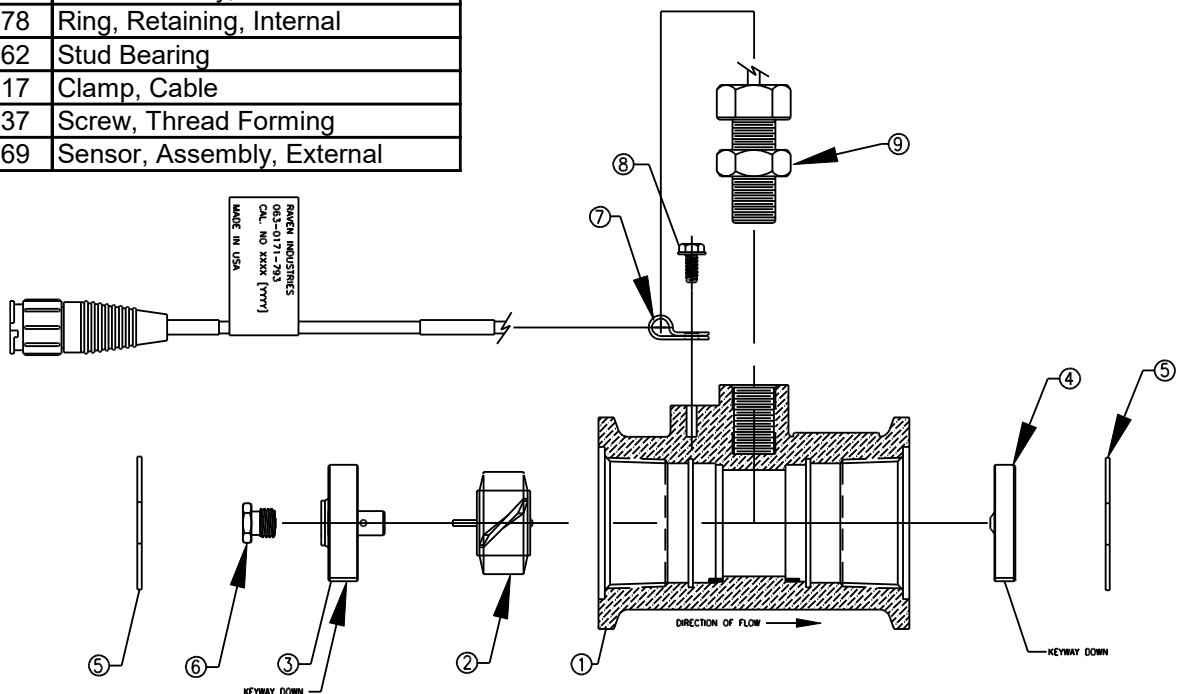

# PL450BEC-FB - Electric Shut-Off Flow Back Ball Valve Manifold

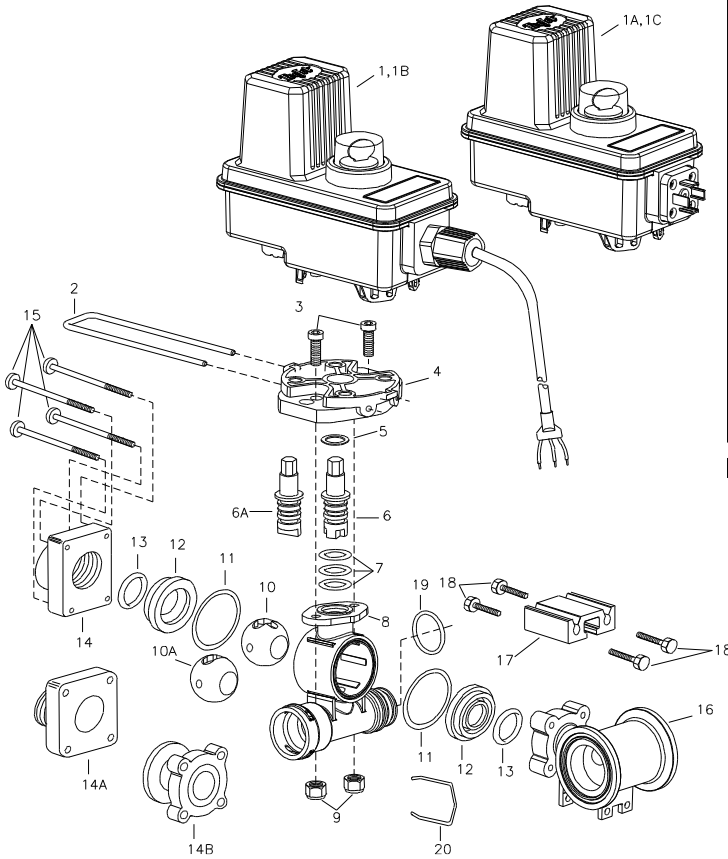

No.	Part #	Part Description
1	50515-22CP03♦	BEC Motor, 22-RPM (0.7-Sec.), 0.3-Meter Cable, Positively Switched
	50515-22CP05♦	BEC Motor, 22-RPM (0.7-Sec.), 0.5-Meter Cable, Positively Switched
	50515-22CP15♦	BEC Motor, 22-RPM (0.7-Sec.), 1.5-Meter Cable, Positively Switched
	50515-22CP60♦	BEC Motor, 22-RPM (0.7-Sec.), 6.0-Meter Cable, Positively Switched
	50515-22DP♦	BEC Motor, 22-RPM (0.7-Sec.), Din Connection, Positively Switched
1A	50533-22C03	BEC Motor, 22-RPM (0.7-Sec.), 0.3-Meter Cable
	50533-22C05	BEC Motor, 22-RPM (0.7-Sec.), 0.5-Meter Cable
	50533-22C15	BEC Motor, 22-RPM (0.7-Sec.), 1.5-Meter Cable
	50533-22C60	BEC Motor, 22-RPM (0.7-Sec.), 6.0-Meter Cable
1B	50533-22D	BEC Motor, 22-RPM (0.7-Sec.), Din Connection
1C	50533-22D	BEC Motor, 22-RPM (0.7-Sec.), Din Connection
2	CP50517-SSPV	Retaining Clip, 304 Stainless Steel
3	CP26197-7/8-SS	Socket Head Cap Screw, 1/4"-20 x 7/8", Stainless Steel (2 Req'd)
4	CP50514-PP	Motor Adapter, Polypropylene (Black)
5	CP20125-TEF	Thrust Washer, Teflon
6	CP56613-SS	Stem, 303 Stainless Steel (for Polypropylene Ball)
6a	CP56615-SS	Stem, 303 Stainless Steel (for Stainless Steel Ball)
7	CP7717-M12X-2.5-VI	O-Ring, Viton (3 Req'd)
8	CP55223-NYB	Flow Back Body, Nylon (Black)
9	CP38435-1/4-SSNY	Elastic Locknut, 1/4"-20, Stainless Steel (2 Req'd)
10	CP20106-2-PP	Flow Back Ball, Polypropylene (White)
10A	CP19926-2-SS	Flow Back Ball, 303 Stainless Steel
11	CP20564-VI	Gasket, Viton (2 Req'd)
12	CP20103-TEF	Seal, Teflon (2 Req'd)
13	CP7717-2-213-VI	O-Ring, Viton (2 Req'd)
14	CP20104-3/4-NYB	End Cap, Nylon (Black) (3/4" NPT Thread)
	CPB20104-3/4-NYB	End Cap, Nylon (Black) (3/4" BSPT Thread)
	CP20104-1-NYB	End Cap, Nylon (Black) (1" NPT Thread)
	CPB20104-1-NYB	End Cap, Nylon (Black) (1" BSPT Thread)
14A	CP45614-NYB	End Cap, Nylon (Black) (Quick Connect)
14B	CP45253-NYB	End Cap, Nylon (Black) (50-Series Flange)
15	CP45252-2-3/4-SSPV	Screw, 1/4"-12 x 2-3/4" Pan Head, Stainless Steel (4 Req'd)
16	CP55224-PP	#75 Narrow Tee Body, Polypropylene (Black)
17	CP45216-AL	Mounting Rail, Aluminum
18	CP45259-SS	Screw, M6 x 1 x 16MM Hex, Stainless Steel (4 Req'd)
19	CP7717-M25X3-VI	O-Ring, Viton
20	CP37166-1-302SS	Quick Connect Retaining Clip, 302 Stainless Steel
	56609-3FB-	Valve Body Sub-Assy, Specify Outlet Size & Ball Material (Includes Items 3-19)
AB344AE-KIT, Spare Parts Kit (Includes All Items Marked with *)		

NOTE: (B) in Part Number Indicates B.S.P.T. Inlet & Outlet Connections  
 ♦ NOTE: For Negatively Switched Motors Specify "N" rather than "P" in Motor Part Number (Ex: 50515-22CN0)  
 NOTE: For Quick Connect Fitting Part Numbers - See Parts List PL45529

Teflon® is a Trademark of Dupont Company  
 Viton® is a Trademark of Dupont Dow Elastomers

# AA(B)126ML-3-\*, AA(B)-4-\*, AA(B)126ML-F50-\* Line Strainers

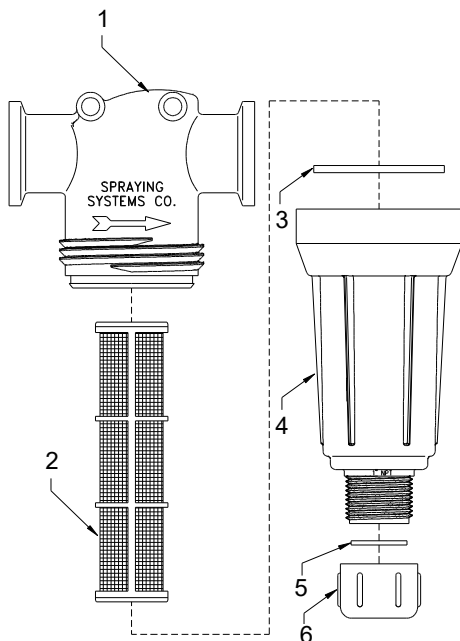

No.	Part #	Part Description
1	CP50491-PP	Strainer Head, Polypropylene (Black) (50-Series Flange)
	CP50492-3/4-PP	Strainer Head, Polypropylene (Black) (3/4" NPT)
	CP50492-1-PP	Strainer Head, Polypropylene (Black) (1" NPT)
	CPB50492-3/4-PP	Strainer Head, Polypropylene (Black) (3/4" BSPT)
	CPB50492-1-PP	Strainer Head, Polypropylene (Black) (1" BSPT)
2	CP16903-1-SSPP	Screen, Stainless Steel w/Polypropylene Frame, 16 Mesh (Gray)
	CP16903-3-SSPP	Screen, Stainless Steel w/Polypropylene Frame, 30 Mesh (Yellow)
	CP16903-4-SSPP	Screen, Stainless Steel w/Polypropylene Frame, 50 Mesh (Red)
	CP16903-5-SSPP	Screen, Stainless Steel w/Polypropylene Frame, 80 Mesh (Blue)
	CP16903-6-SSPP	Screen, Stainless Steel w/Polypropylene Frame, 100 Mesh (Green)
3	CP16903-7-SSPP	Screen, Stainless Steel w/Polypropylene Frame, 200 Mesh (Orange)
	CP50494-EPR*	Gasket, EPDM Rubber
4	CP50494-VI**	Gasket, Viton
	CP50493-PP	Bowl, Polypropylene (Gray) (1" NPT)
5	CPB50493-PP	Bowl, Polypropylene (Gray) (1" BSPT)
	CP63150-EPR*	Gasket, EPDM Rubber
6	CP63150-VI**	Gasket, Viton
	CP48655-PP	Cap, Polypropylene (Gray)

AB126ML-50-EPR-KIT - Repair Kit, Contains Items Marked with \*  
 AB126ML-50-VI-KIT - Repair Kit, Contains Items Marked with \*\*  
 No. AA126ML-F50-\_\_ (VI) Liquid Strainer (50-Series Flange Connections) (Viton Optional)  
 No. AAB126ML-F50-\_\_ (VI) Liquid Strainer (50-Series Flange Connections) (Viton Optional)  
 No. AA126ML-3-\_\_ (VI) Liquid Strainer (3/4" NPT Connections) (Viton Optional)  
 No. AA126ML-4-\_\_ (VI) Liquid Strainer (1" NPT Connections) (Viton Optional)  
 No. AAB126ML-3-\_\_ (VI) Liquid Strainer (3/4" BSPT Connections) (Viton Optional)  
 No. AAB126ML-4-\_\_ (VI) Liquid Strainer (1" BSPT Connections) (Viton Optional)

# Technical Details

**Operating Pressure (max):** Inlet 3000 PSI (207 bar)      Outlet: 3000 PSI (207 bar)  
**Regulated Flow (max):** 14 GPM (53 LPM) - Bypass Port Plugged (0 gpm Bypass)  
 15 GPM (57 LPM) - Bypass Port Open (15 gpm Max Bypass)

**Electrical:**

Voltage: 12 VDC  
 Frequency: 110 Hz  
 Valve Type: Normally Closed Proportional Flow Control  
 Threshold (Activation) Current: 350+/-100 mA  
 Max. Control Current: 1600+/-200 mA

**Initial Current Draw: 2.7 amps**

**Power: 32.8 watts**

**Resistance: 4.5 ohms at 68 degree F (20 degree C)**

**Storage Temperature: 32 to 140 degrees F (0 to 60 degrees C)**

**Fluids: Mineral based or synthetic hydraulic fluid at viscosities of 7.4 to 420 cSt**

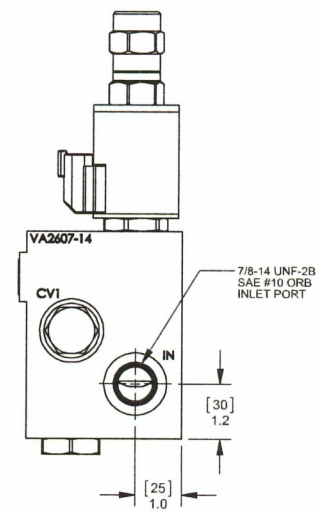
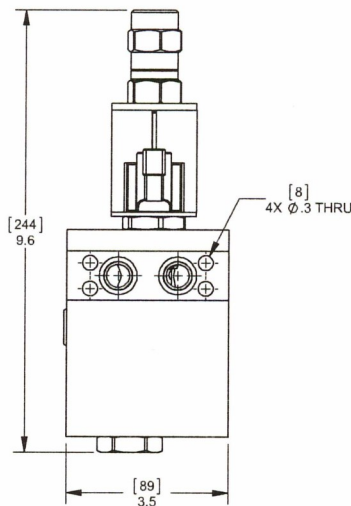
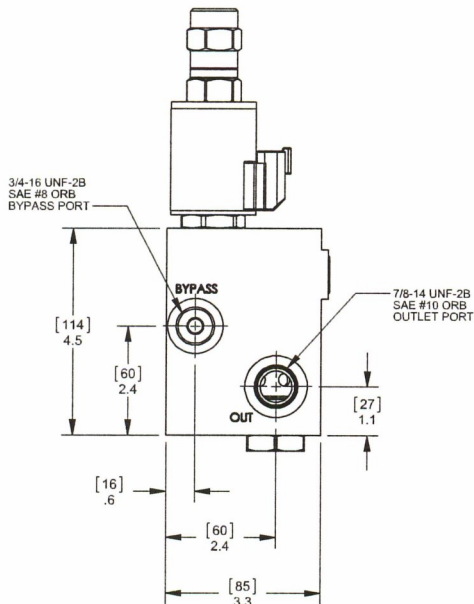
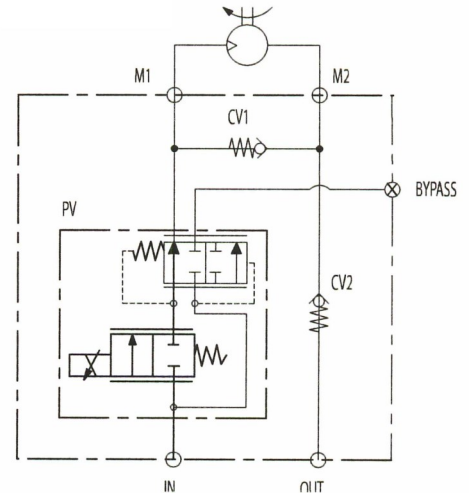

The Hypro hydraulic control assembly is designed to directly mount to modified Hypro HM series hydraulic motors. The control assembly provides a convenient solution for increased efficiency and damage prevention from abuse conditions.

# Operation Instructions

The hydraulic control assembly is designed to work with a digital controller with PWM signal output. As the signal current increases, the hydraulic flow control valve opens.

To ensure proper hydraulic oil flow metering, follow the calibration procedure described by the manufacturer of the controller that is being used as each controller's procedure is different. In general, balancing reaction time and system stability are key to proper calibration.

The hydraulic flow control valve has a manual override option fitted from the factory. This feature can be used to open or close the valve in the event that the digital controller has an error or fails. To use this feature, remove the override cover on the top of the valve to reveal the red override toggle. The override is engaged by turning the toggle clockwise. One full turn is required to start opening the valve and full open is achieved with 6 full turns. To close the valve, turn the toggle counter clockwise 6 turns until a stop is reached.

Connections to the control assembly are SAE #10 (7/16-14 UNF-2B) O-ring boss ports. Ensure that the mating fitting has an O-ring free of any debris or damage before installation.

Match the high pressure line to the port labelled "IN" and the low pressure line back to tank to the port labelled "OUT".

The port labelled "BYPASS" is a SAE #8 (3/4-16 UNF-2B) port intended return excess oil flow back to the reservoir. This port comes plugged from the factory. When plugged, the hydraulic control assembly can be used with the hydraulic circuits that have a variable displacement pump. If the hydraulic circuit uses a fixed displacement pump, the plug must be removed and a line should be run from the bypass port to the reservoir. The maximum input flow is 30 GPM (114 LPM) for the bypass configuration.

No.	Part #	Description	Qty.	Included in 3430-0876 Service Kit
1	2500-0144C	Hydraulic Motor, HM1	1	
2	2210-0217	Bolt	4	X
3	0204-2500C5	Motor End Cover	1	X
4	3320-0079	Valve, Check-12	1	
5	3320-0078	Valve, Check-10	1	
6	3320-0080	Valve, Flow Control HM1	1	
6B	3320-0081	Valve, Flow Control HM4	1	
7	2525-0036	Solenoid	1	
8	2220-0129	Screw	4	X
9	2404-0443	Hydraulic Control Assy HM1	1	X
9B	2404-0452	Hydraulic Control Assy HM4	1	
-	2520-0212	Cable	1	

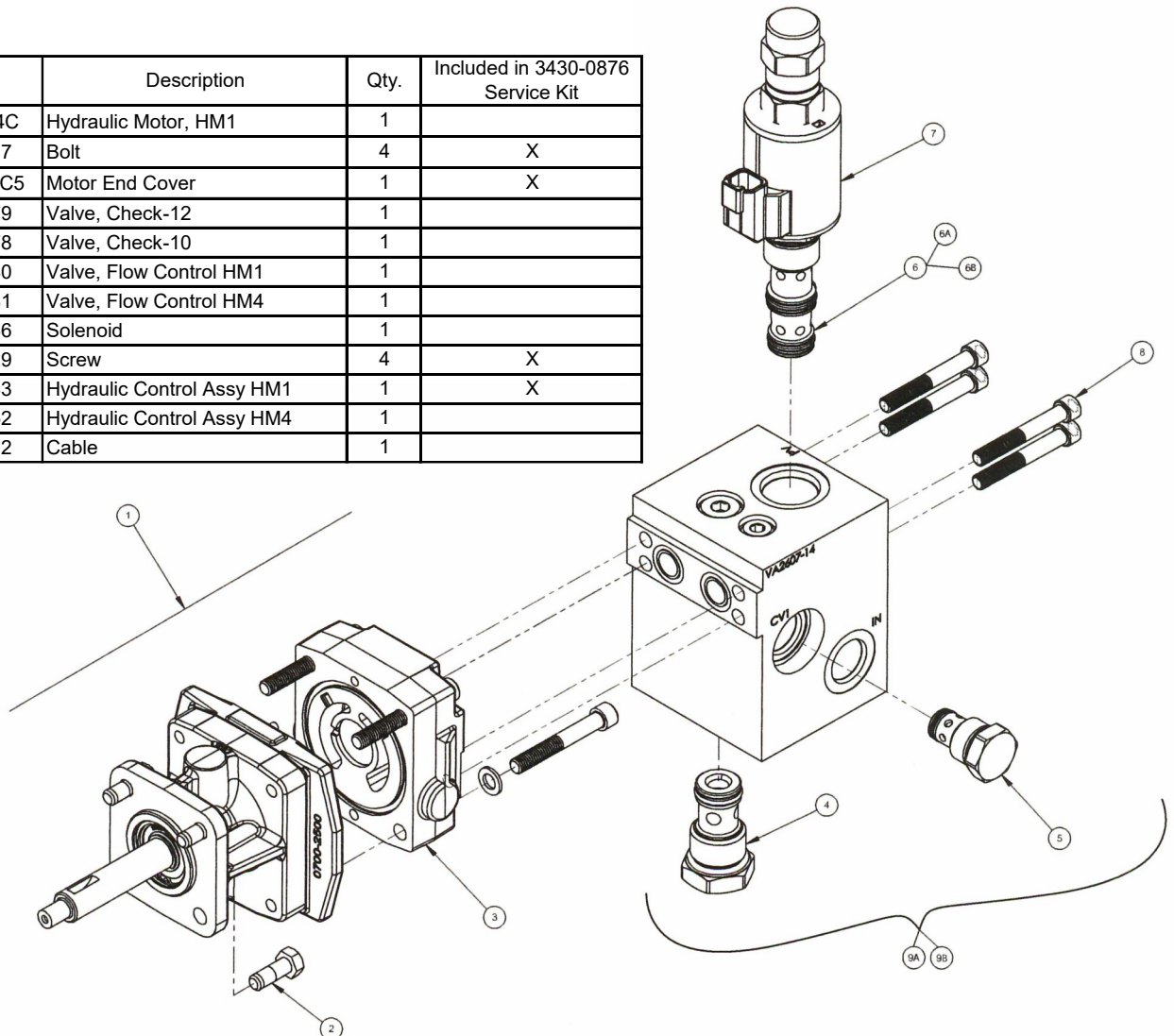



## Service Instructions

The three valves used in the hydraulic control assembly are screw-in cartridge type valves and are replaceable. Each valve must be installed with the correct tightening torque to ensure proper operation. If the valve is tightened above the specified torque value, the valve internals may be damaged causing the valve to stick.

Before installing a new valve, inspect the valve to ensure all O-rings are seated in their appropriate grooves and have no damage, such as nicks or cuts.

Lubricate all O-rings with the oil being used in the hydraulic circuit. This will ensure the valve can slide into the cavity without dislodging or damaging the O-rings.

Screw in the new valve and tighten to the following specifications:

Valve	Cavity Label	Torque (Ft-Lbs) (Nm)
PV72-30 Flow Control	PV	33-37 (44.7-50.2)
Check Valve	CV1	24-26 (32.5-35.3)
Check Valve	CV2	33-37 (44.7-50.2)

## Troubleshooting

Symptom	Corrective Action(s)
No flow from the pump	Engage the manual override on the flow control valve and send hydraulic flow to the motor. If no pump output is generated check the tractor hydraulic system for adequate supply flow and pressure or check the pump troubleshooting guide for pump evaluation.
No flow from the pump	Measure the resistance of the valve solenoid coil with an ohmmeter. The nominal resistance of the solenoid coil is 4.5 ohms. If the resistance rating is near zero or very high, the solenoid may be
Unstable pump performance	Review controller settings. Valve is normally closed, 110Hz PWM frequency. Decreasing brake point and/or increasing dead band tolerance settings incrementally may help improve stability.
Unable to get agitation flow	Review controller procedure for pump operation for manual control or methods for sending PWM signal to the valve while no flow is being detected by system flowmeters.

# Limited Warranty on Hypro/Shurflo Agricultural Pumps & Accessories

Hypro/Shurflo (hereafter, "Hypro") agricultural products are warranted to be free of defects in material and workmanship under normal use for the time periods listed below, with proof of purchase.

- Pumps: one (1) year from the date of manufacture or one (1) year of use.  
This limited warranty will not exceed two (2) years, in any event.
- Accessories: ninety (90) days of use.

This limited warranty will not apply to products that were improperly installed, misapplied, damaged, altered or incompatible with fluids or components not manufactured by Hypro. All warranty considerations were governed by Hypro's written return policy.

Hypro's obligation under this limited warranty policy is limited to the repair or replacement of the product. All returns will be tested per Hypro's factory criteria. Products found not defective (under the terms of this limited warranty) are subject to charges paid by the returnee for the testing and packaging of "tested good" non-warranty returns.

No credit or labor allowances will be given for products returned as defective. Warranty replacement will be shipped on a freight allowed basis. Hypro reserves the right to choose the method of transportation.

This limited warranty is in lieu of all other warranties, expressed or implied and no other person is authorized to give any other warranty or assume obligation or liability on Hypro's behalf. Hypro shall not be liable for any labor, damage or other expense, nor shall Hypro be liable for any indirect, incidental or consequential damages of any kind incurred by the reason of the use or sale of any defective product. This limited warranty covers agricultural products distributed within the United States of America. Other world market areas should consult with the actual distributor for any deviation from this document.

## 9306C-HM1C-BU-002 Pump

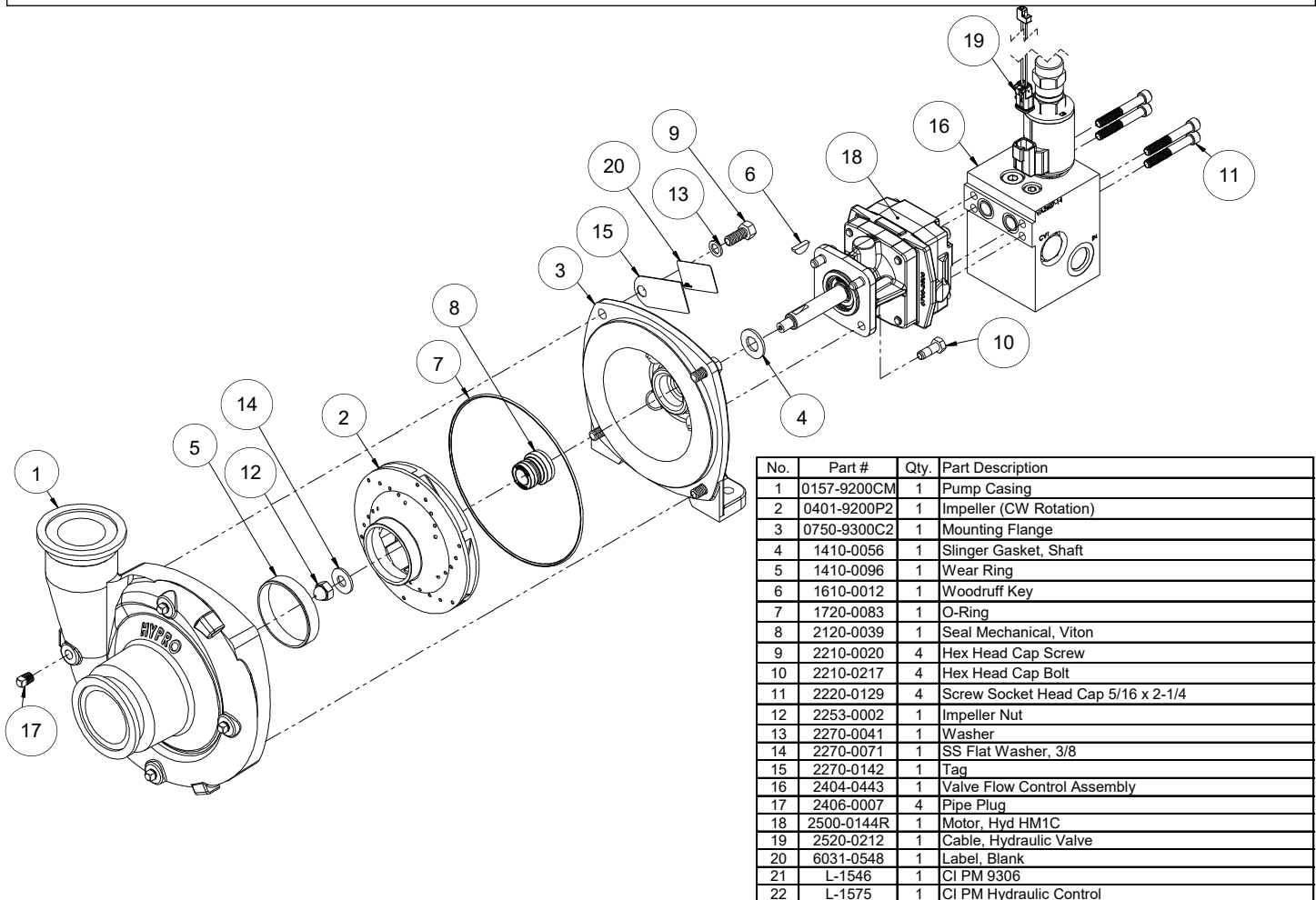

# Ag Spray Warranty Info

## LIMITED WARRANTY FOR NEW AG SPRAY EQUIPMENT

**WHO MAY USE THIS LIMITED WARRANTY.** This limited warranty (the "Limited Warranty") is provided by Fimco, Inc. ("Ag Spray Equipment") to the original purchaser ("you") of the Equipment (as defined below) from Ag Spray Equipment or one of Ag Spray Equipment's authorized dealers. This Limited Warranty does not apply to any subsequent owner or other transferee of the Equipment. THIS LIMITED WARRANTY GIVES YOU SPECIFIC LEGAL RIGHTS, AND YOU MAY ALSO HAVE OTHER RIGHTS WHICH VARY FROM STATE TO STATE.

**WHAT THIS LIMITED WARRANTY COVERS AND FOR HOW LONG.** Ag Spray Equipment warrants that any new Equipment will be free from defects in material and workmanship for a period of **one (1) year** (homeowner), **90 days** (commercial user), after delivery of the Equipment to you (the "Warranty Period"). The Warranty Period is not extended if Ag Spray Equipment repairs or replaces the Equipment.

**WHAT IS NOT COVERED BY THIS LIMITED WARRANTY.** This Limited Warranty does not apply to: (1) used Equipment; (2) any Equipment that has been altered, changed, repaired or treated since its delivery to you, other than by Ag Spray Equipment or its authorized dealers; (3) damage or depreciation due to normal wear and tear; (4) defects or damage due to failure to follow Ag Spray Equipment's operator's manual, specifications or other written instructions, or improper storage, operation, maintenance, application or installation of parts; (5) defects or damage due to misuse, accident or neglect, "acts of God" or other events beyond Ag Spray Equipment's reasonable control; (6) accessories, attachments, tools or parts that were not manufactured by Ag Spray Equipment, whether or not sold or operated with the Equipment; or (7) rubber parts, such as tires, hoses and grommets.

**HOW TO OBTAIN WARRANTY SERVICE.** To obtain warranty service under this Limited Warranty, you must (1) provide written notice to Ag Spray Equipment of the defect during the Warranty Period and within **thirty (30) days** after the defect becomes apparent or the repair becomes necessary, at the following address: Ag Spray Equipment, 1000 Fimco Lane, North Sioux City, SD 57049; and (2) make the Equipment available to Ag Spray Equipment or an authorized dealer within a reasonable period of time. For more information about this Limited Warranty, please call: **800-274-1025**

**WHAT REMEDIES ARE AVAILABLE UNDER THIS LIMITED WARRANTY.** If the conditions set forth above are fulfilled and the Equipment or any part thereof is found to be defective, Ag Spray Equipment shall, at its own cost, and at its option, either repair or replace the defective Equipment or part. Ag Spray Equipment will pay for shipping and handling fees to return the repaired or replacement Equipment or part to you.

**LIMITATION OF IMPLIED WARRANTIES AND OTHER REMEDIES.** THE REMEDIES DESCRIBED ABOVE ARE YOUR SOLE AND EXCLUSIVE REMEDIES, AND AG SPRAY EQUIPMENT'S SOLE LIABILITY, FOR ANY BREACH OF THIS LIMITED WARRANTY. TO THE EXTENT APPLICABLE, ANY IMPLIED WARRANTIES, INCLUDING, WITHOUT LIMITATION, THE IMPLIED WARRANTIES OF MERCHANTABILITY AND FITNESS FOR A PARTICULAR PURPOSE, SHALL BE LIMITED IN DURATION TO THE WARRANTY PERIOD, AND THE REMEDIES AVAILABLE FOR BREACH THEREOF SHALL BE LIMITED TO THE REMEDIES AVAILABLE UNDER THIS EXPRESS LIMITED WARRANTY. SOME STATES DO NOT ALLOW LIMITATIONS ON HOW LONG AN IMPLIED WARRANTY LASTS, SO THE ABOVE LIMITATION MAY NOT APPLY TO YOU. IN NO EVENT SHALL AG SPRAY EQUIPMENT'S LIABILITY UNDER THIS LIMITED WARRANTY EXCEED THE ACTUAL AMOUNT PAID BY YOU FOR THE DEFECTIVE EQUIPMENT, NOR SHALL AG SPRAY EQUIPMENT BE LIABLE, UNDER ANY CIRCUMSTANCES, FOR ANY CONSEQUENTIAL, INCIDENTAL, SPECIAL OR PUNITIVE DAMAGES OR LOSSES, WHETHER DIRECT OR INDIRECT. SOME STATES DO NOT ALLOW THE EXCLUSION OR LIMITATION OF INCIDENTAL OR CONSEQUENTIAL DAMAGES, SO THE ABOVE LIMITATION OR EXCLUSION MAY NOT APPLY TO YOU.

# 7000 SERIES SPRAYER

1350 Gallon Tank w/60', 80' or 90' Boom & Dual Option



05/23



**BAKERSFIELD, CA**  
4618 SACO RD, 93308  
**661.391.9081**  
Toll Free: 877.724.2236  
F: 661.391.9085  
[BAKERSFIELD@AGSPRAY.COM](mailto:BAKERSFIELD@AGSPRAY.COM)

**COLUMBUS, NE**  
5834 23rd ST, 68601  
**402.564.4544**  
Toll Free: 800.274.1025  
F: 402.564.0549  
[COLUMBUS@AGSPRAY.COM](mailto:COLUMBUS@AGSPRAY.COM)

**DOTHAN, AL**  
2401 FORRESTER RD, 36301  
**334.673.0580**  
Toll Free: 800.227.4098  
F: 334.673.1974  
[DOTHAN@AGSPRAY.COM](mailto:DOTHAN@AGSPRAY.COM)

**FARGO, ND**  
4350 48th AVE N, 58102  
**701.280.2862**  
Toll Free: 800.373.4084  
F: 701.293.0961  
[FARGO@AGSPRAY.COM](mailto:FARGO@AGSPRAY.COM)

**HOPKINSVILLE, KY**  
3303 PEMBROKE RD, 42240  
**270.886.0296**  
Toll Free: 800.637.7172  
F: 270.885.7392  
[HOPKINSVILLE@AGSPRAY.COM](mailto:HOPKINSVILLE@AGSPRAY.COM)

**MANKATO, MN**  
907 SOUTHBEND AVE, 56001  
**507.377.6295**  
Toll Free: 800.722.9376  
F: 507.388.4668  
[MANKATO@AGSPRAY.COM](mailto:MANKATO@AGSPRAY.COM)

**NEWTON, KS**  
7000 SCHABEN CT, 67114  
**316.283.4444**  
Toll Free: 800.394.7662  
F: 316.293.4646  
[NEWTON@AGSPRAY.COM](mailto:NEWTON@AGSPRAY.COM)

**PASCO, WA**  
3035 TRAVEL PLAZA WAY, 99301  
**509.488.6631**  
Toll Free: 800.634.2026  
F: 509.488.2927  
[OTHELLO@AGSPRAY.COM](mailto:OTHELLO@AGSPRAY.COM)

**TEMPE, AZ**  
8464 KYRENE RD, 85284  
**480.705.8047**  
Toll Free: 877.705-8047  
F: 480.705.8048  
[TEMPE@AGSPRAY.COM](mailto:TEMPE@AGSPRAY.COM)